



# TECHNICAL GUIDE

## *PROFILEMASTER PLUS AL*

**SWF Krantechnik GmbH**  
Postbox 310410  
68264 Mannheim  
Germany

X122526en / A / 14 Mar 2018  
231 015 44

Boehringerstraße 4  
68307 Mannheim  
Germany

tel +49(0)621 789 90-0  
fax +49(0)621 789 90-100  
Info@swfkrantechnik.com  
www.swfkrantechnik.com

### ORIGINAL INSTRUCTIONS



## TABLE OF CONTENTS

<b>1</b>	<b>MANUFACTURER.....</b>	<b>7</b>
<b>2</b>	<b>SUPPLEMENTARY DOCUMENTS AND OTHER MANUALS.....</b>	<b>8</b>
<b>3</b>	<b>PROFILEMASTER PLUS AL CRANE CONSTRUCTION KIT.....</b>	<b>9</b>
<b>3.1</b>	<b>General.....</b>	<b>9</b>
<b>3.2</b>	<b>Structure of the crane construction kit.....</b>	<b>10</b>
<b>3.3</b>	<b>Design principles.....</b>	<b>10</b>
3.3.1	Smooth-running characteristics.....	10
3.3.2	Profile sections.....	10
3.3.3	Suspension system.....	11
3.3.4	Horizontal forces.....	11
3.3.5	Trolleys.....	11
3.3.6	Travel drives.....	12
3.3.7	Combined crane installations.....	12
3.3.8	Push-travel cranes.....	12
3.3.9	Electric travel cranes.....	12
3.3.10	Power supply.....	12
3.3.11	Electric and control equipment.....	12
3.3.12	Corrosion protection.....	12
3.3.13	Ambient conditions.....	13
<b>4</b>	<b>PROFILEMASTER PLUS AL CLASSIC – PLANNING AND PROJECT DRAFTING</b>	<b>14</b>
<b>4.1</b>	<b>Project drafting of suspension crane installations.....</b>	<b>14</b>
<b>4.2</b>	<b>ProfileMaster PLUS AL product configurator.....</b>	<b>14</b>
<b>4.3</b>	<b>Examples and symbols.....</b>	<b>14</b>
<b>4.4</b>	<b>Project planning sheet for ProfileMaster PLUS AL installations.....</b>	<b>16</b>
<b>4.5</b>	<b>Profile load capacities according to the diagram.....</b>	<b>17</b>
<b>4.6</b>	<b>Steps for project planning and technical specification.....</b>	<b>19</b>
<b>4.7</b>	<b>Reading off from the diagram.....</b>	<b>19</b>
4.7.1	Crane span dimension $l_{kr}$ .....	19
4.7.2	Distance between suspensions $l_w$ .....	19
4.7.3	Concentrated load.....	19
4.7.4	Several loads.....	19
4.7.5	Two identical loads or load bar.....	20
4.7.6	More than two identical loads at equal distances.....	20
<b>4.8</b>	<b>Calculating load GAB on one suspension fitting.....</b>	<b>20</b>
4.8.1	Concentrated load.....	20
4.8.2	Two or more loads in one of the two panels between suspensions.....	21
4.8.3	Two loads or groups of loads at a distance $e_{KT}$ .....	21
<b>4.9</b>	<b>System dimensions and system limits.....</b>	<b>21</b>
4.9.1	Overhang.....	21
4.9.2	Crane overhang.....	22
4.9.3	Track overhang.....	22
4.9.4	Approach dimension.....	22
4.9.5	Permissible distance of joint from suspension $st$ .....	22
4.9.6	Drive.....	22
4.9.7	Deflection.....	22
<b>4.10</b>	<b>Hoists with ProfileMaster PLUS AL.....</b>	<b>23</b>
<b>4.11</b>	<b>Single and double-girder cranes.....</b>	<b>23</b>
4.11.1	Single-girder crane.....	23
4.11.2	Double-girder crane.....	24

4.11.3	Specifying single and double-girder cranes according to selection tables....	25
<b>4.12</b>	<b>Structural dimensions for cranes.....</b>	<b>36</b>
<b>5</b>	<b>CRANE RUNWAY AND CRANE GIRDER BASIC COMPONENTS.....</b>	<b>38</b>
<b>5.1</b>	<b>Crane and track elements.....</b>	<b>38</b>
5.1.1	Straight section (item 1).....	38
5.1.2	Aligning device.....	39
<b>5.2</b>	<b>Joint bolt set (item 2) and conductor joint set (item 3).....</b>	<b>40</b>
<b>5.3</b>	<b>Internal buffer stop (item 6).....</b>	<b>40</b>
<b>5.4</b>	<b>End cap with buffer (item 7) (item 7e).....</b>	<b>41</b>
<b>5.5</b>	<b>AL-R components.....</b>	<b>42</b>
5.5.1	Powerfeed end cap (item 8).....	42
5.5.2	DFL fixed points (item 210).....	43
5.5.3	Current collector trolley (item 12).....	43
<b>5.6</b>	<b>Information plates.....</b>	<b>44</b>
<b>6</b>	<b>TRACK SUSPENSION.....</b>	<b>45</b>
<b>6.1</b>	<b>Notes and overview.....</b>	<b>45</b>
<b>6.2</b>	<b>Vertical suspension on I-beams.....</b>	<b>47</b>
6.2.1	I-beam assignment.....	47
6.2.2	Suspension with suspension rod.....	48
6.2.3	Coupling for suspension rod (item 50).....	50
6.2.4	Short suspension arrangement with height adjustment.....	51
<b>6.3</b>	<b>Vertical suspension from U-sections.....</b>	<b>52</b>
<b>6.4</b>	<b>Ceiling attachment.....</b>	<b>53</b>
6.4.1	Suspension with anchor bolt connection.....	53
6.4.2	U-bolt with upper suspension bracket A.....	53
6.4.3	Suspension from ceiling section rails with upper suspension bracket A.....	53
6.4.4	Suspension with floor fixture plate and cover.....	54
6.4.5	Suspension with upper suspension bracket A and suspension rods or positive anchors.....	55
<b>6.5</b>	<b>V-type suspension fitting.....</b>	<b>56</b>
<b>6.6</b>	<b>Stiffener.....</b>	<b>57</b>
<b>6.7</b>	<b>Component parts for V-type suspension/stiffener arrangement.....</b>	<b>58</b>
6.7.1	V-type upper suspension bracket (item 46).....	58
6.7.2	Packing plate for upper suspension bracket.....	60
6.7.3	V-type hinged suspension clamp (item 47).....	60
6.7.4	Spring clip (item 43), suspension rod strainer (item 48) and hinged end piece (item 49).....	61
6.7.5	Wall fixture.....	62
<b>6.8</b>	<b>Determining suspension rod length h1 for V-type suspensions and stiffeners..</b>	<b>63</b>
<b>7</b>	<b>TROLLEY COMBINATIONS.....</b>	<b>64</b>
<b>7.1</b>	<b>Single trolleys.....</b>	<b>64</b>
<b>7.2</b>	<b>Double trolleys.....</b>	<b>64</b>
<b>7.3</b>	<b>Load bars for travel on straight tracks for trolleys and cranes with a supporting pin.....</b>	<b>65</b>
7.3.1	Load bar 600 (items 59, 60).....	65
7.3.2	Type A load bar (item 59).....	65
<b>7.4</b>	<b>Load bars for travel on straight tracks for trolleys and cranes with two supporting pins.....</b>	<b>66</b>
7.4.1	Type B load bar (item 66).....	66



<b>7.5</b>	<b>Classic crane end carriages.....</b>	<b>67</b>
7.5.1	Frame for double-girder crane (item 63).....	67
7.5.2	Rigid single-girder crane end carriage (item 62).....	68
<b>8</b>	<b>DOUBLE-RAIL CRAB.....</b>	<b>69</b>
<b>9</b>	<b>CRANE SUSPENSION EYE.....</b>	<b>71</b>
<b>10</b>	<b>TRAVEL DRIVES FOR CRABS AND CRANES.....</b>	<b>72</b>
<b>10.1</b>	<b>RF 125 friction-wheel travel drive.....</b>	<b>72</b>
10.1.1	Drive data.....	72
10.1.2	Control system.....	72
10.1.3	RF 125 rocker (item 135).....	73
10.1.4	Possible mounting configurations.....	73
<b>10.2</b>	<b>Travel limit switches.....</b>	<b>75</b>
<b>11</b>	<b>TROLLEYS FOR TRAVEL DRIVES.....</b>	<b>77</b>
<b>12</b>	<b>COUPLING ELEMENTS AND SPACER BARS.....</b>	<b>78</b>
<b>12.1</b>	<b>Link for single trolley (item 61).....</b>	<b>78</b>
<b>12.2</b>	<b>165 trolley coupling/long link bar.....</b>	<b>78</b>
<b>12.3</b>	<b>Articulated spacer bars (items 72, 73).....</b>	<b>79</b>
<b>12.4</b>	<b>Spacer bars for straight track, AL18/AL22.....</b>	<b>80</b>
<b>13</b>	<b>BUFFERS AND END STOPS.....</b>	<b>82</b>
<b>13.1</b>	<b>Buffers on crabs and cranes outside the profile section.....</b>	<b>82</b>
<b>13.2</b>	<b>Buffer on AL18/AL22 single trolley inside the profile section .....</b>	<b>83</b>
<b>14</b>	<b>POWER SUPPLY TO CRABS AND CRANES.....</b>	<b>84</b>
<b>14.1</b>	<b>Trailing cable, general information.....</b>	<b>84</b>
<b>14.2</b>	<b>Trailing cable, components and fittings.....</b>	<b>85</b>
14.2.1	Rail end cable clamp (item 83), flat cable with PE (item 84), cable slider (item 85) and cable trolley (item 86).....	85
14.2.2	Crane girder cable clamp (item 80).....	86
14.2.3	Crab frame cable clamp (item 81).....	86
14.2.4	RF trolley cable clamp (item 82).....	87
<b>14.3</b>	<b>Round cable and crane drive connection.....</b>	<b>87</b>
<b>14.4</b>	<b>Mains connection switch/isolating switch (item 88).....</b>	<b>88</b>
<b>14.5</b>	<b>Terminal box (item 94).....</b>	<b>89</b>
<b>14.6</b>	<b>Mounting brackets for switches and terminal boxes.....</b>	<b>89</b>
14.6.1	Mounting bracket for terminal box (item 92).....	89
14.6.2	Mounting bracket for enclosure on RF 125 (item 92).....	90
14.6.3	Attachment bracket (item 93).....	91
14.6.4	Bracket for isolating switch (item 90).....	91
<b>15</b>	<b>PROFILEMASTER PLUS AL STANDARD ELECTRIC EQUIPMENT.....</b>	<b>92</b>
<b>15.1</b>	<b>General.....</b>	<b>92</b>
<b>15.2</b>	<b>Standard electric equipment.....</b>	<b>93</b>
<b>15.3</b>	<b>Cable union sets (items 190, 191).....</b>	<b>93</b>
<b>15.4</b>	<b>Schematic diagrams of cable arrangements and cable clamps.....</b>	<b>94</b>



# 1 MANUFACTURER

## **SWF Krantechnik GmbH**

Boehringerstraße 4

D-68307 MANNHEIM

GERMANY

[www.swfkrantechnik.com](http://www.swfkrantechnik.com)

## 2 SUPPLEMENTARY DOCUMENTS AND OTHER MANUALS

<b>Technical data</b>	ProfileMaster PLUS ST technical guide	231 013 44
	Anchor bolt connection	231 014 44
<b>Operating instructions</b>	ProfileMaster PLUS AL suspension crane operator's manual	231 017 44
	Chain hoist operating instructions	Included in the chain hoist scope of delivery.

## 3 PROFILEMASTER PLUS AL CRANE CONSTRUCTION KIT

### 3.1 General

The ProfileMaster PLUS AL crane construction kit is the efficient and reliable solution for the construction of suspension cranes made of aluminum profile sections.

The use of aluminum profile sections improves installation ergonomics. Lower crane bridge deadweights and extremely low rolling resistance further reduce the required travel forces.

The ProfileMaster PLUS AL crane construction kit consists of standardized mechanical and control components. This facilitates planning, erection and maintenance. Installations can be altered and extended at any time.

The installations can be easily adapted to new material handling requirements. ProfileMaster PLUS AL crane installations utilize the free space above working and production areas. Valuable production floor space is not sacrificed for materials handling tasks.

#### Regulations

ProfileMaster PLUS AL installations are dimensioned on the basis of the DIN 15018 standard. The material properties of aluminum have been taken into consideration.

Relevant industrial safety regulations and codes of practice as stipulated in DGUV Regulation 52 crane accident prevention regulations must be observed for planning, project engineering and operating ProfileMaster PLUS AL installations.

ProfileMaster PLUS AL cranes designed in accordance with the project planning instructions contained in this guide are manufactured in accordance with generally accepted engineering standards and comply with relevant codes of practice concerning the safeguarding of machinery and prevention of accidents, including German technical equipment legislation, accident prevention (UVV) and DIN VDE regulations, and the EC Machinery Directive.

The declaration of incorporation or declaration of conformity is supplied.

Instructions in the operating and assembly instructions must be complied with.

#### Spare parts

**We urgently recommend that only spare parts and accessories approved by us be used. Only then can we ensure the safety and normal service life of the equipment.**

Spare parts not approved by us can cause damage, malfunctions or complete failure of the installation.

The use of unauthorized spare parts may render null and void any claims for warranty, service, damages or liability against the manufacturer or his appointed personnel, dealers and representatives.

#### Inspection

ProfileMaster PLUS AL suspension cranes require little maintenance. However, 1-2 months after an installation is put into operation, all bolted connections of suspension fittings, track sections and end caps, the pins/bolts connecting hoists to trolleys, and crane girders to runway and track trolleys should be checked and retightened or secured as necessary. This check should be repeated at least once a year.

**For further information see “ProfileMaster PLUS AL operating manual”, see [Supplementary documents and other manuals \(page 8\)](#).**

#### Information

**It is important that all members of staff responsible for erection, safe operation and maintenance of ProfileMaster PLUS AL installations receive the ProfileMaster PLUS AL operating instructions and all relevant documents.**

## 3.2 Structure of the crane construction kit

### General

ProfileMaster PLUS AL installations are of modular design. The basic construction kit consists of simple, well engineered components. Standardized connection dimensions ensure rapid erection and allow existing installations to be easily modified or extended. All components are manufactured in series.

The modular construction kit is designed for normal operating conditions.

### Classic

The ProfileMaster PLUS AL crane construction kit is designed for suspended loads with centric load transmission.

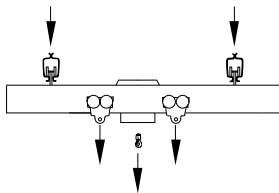

## 3.3 Design principles

- Project planning/engineering based on reliable static analysis
- Series-produced standard components which have been thoroughly tried and tested
- Tailored installations designed for full compliance with safety regulations and standards
- Low-maintenance systems
- Simple, fast erection
- Detailed technical documentation

### 3.3.1 Smooth-running characteristics

AL equipment is designed for the best possible ergonomics.

Note that the smooth-running characteristics of suspension crane systems depend on several factors. These include:

- quality of the trolleys (see [Single trolleys \(page 64\)](#)),
- deadweights,
- specification of the rail system with reference to deflection,
- position of the load on the crane,
- precision of assembly/installation, e.g.
  - alignment of the rails with reference to each other at joints in the track,
  - alignment of the crane runway to the support superstructure,
  - rigidity of the support superstructure,
  - general ambient conditions (dust, dirt, etc.)

When correctly specified and installed, AL equipment offers excellent smooth-running characteristics without any unwanted motions or the need for additional effort to stop the load.

### 3.3.2 Profile sections

The basic elements of the ProfileMaster PLUS AL construction kit are special extruded profile sections made of aluminum with high rigidity optimized by hollow sections, low deadweight and anodized surfaces. The rails are of inside-running design to protect the trolleys. Lateral attachment slots offer a wide variety of connection possibilities for fittings of all types. The underside forms a running surface for counter-pressure rollers.

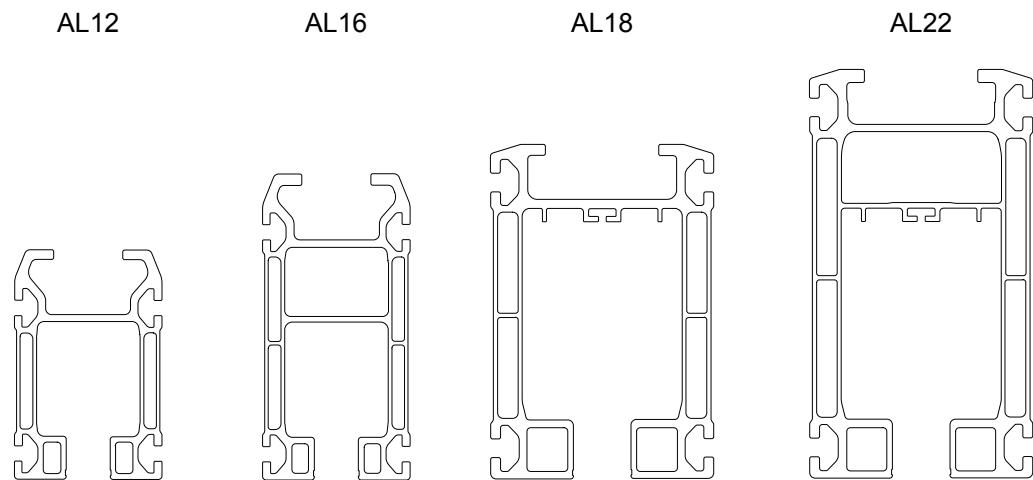

### 3.3.3 Suspension system

- Flexible track suspension (minimum lateral forces transmitted to the track system)
- Ball-and-socket universal joint suspension (minimum torque transmission to roof and ceiling superstructures)
- Low-maintenance ball-and-socket joints with plastic sockets
- Threaded connections for height adjustment
- Spring clip through cross hole locks connection
- Universal suspension fittings for virtually any superstructure – provided as standard
- High suspension load-bearing capacities adapted to the rail system
- Low headroom dimension possible with short suspension fittings

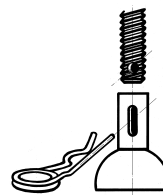
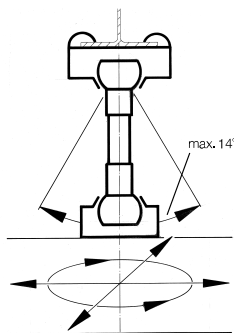

### 3.3.4 Horizontal forces

Only minimum horizontal forces are transmitted to the support superstructure thanks to the articulated suspension design.

For cranes, this does not exceed 10% of trolley load K.

### 3.3.5 Trolleys

- Quiet, smooth operation with plastic travel wheels mounted in anti-friction bearings
- High vertical load-bearing capacity
- Long service life
- Horizontally guided in the track profile
- Flexible and torque-free load connection via pin
- Horizontal load-bearing capacity up to 10% of the suspended vertical load
- Trolleys can be removed from any point along the track

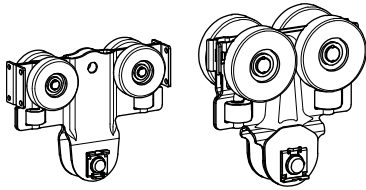

**3.3.6 Travel drives**

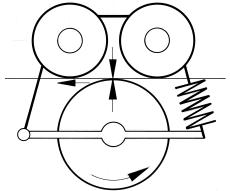

Quiet-running friction wheels with a high friction coefficient ensure reliable transmission of the drive torque. They can be used with special trolleys. Pressure applied by springs.

**3.3.7 Combined crane installations**

Cranes and crane runways made of different section types can be combined. Tracks and crane girders made of aluminum and steel profile sections can also be combined.

**3.3.8 Push-travel cranes**

No skewing forces and flexibility of the tracks on ball-and-socket universal joint suspensions.



**3.3.9 Electric travel cranes**

Single-girder and double-girder designs with rigid crane trolleys or as braced double-girder cranes.

**3.3.10 Power supply**

Flat cable power lines on cable sliders and power supply systems with cable trolleys run in the same track section.

Profile sizes AL18 and AL22 can be provided with a 5-pole internal conductor line.

**3.3.11 Electric and control equipment**

Standard controls for push-travel and electric-travel trolleys and cranes with hoists.

**3.3.12 Corrosion protection**

ProfileMaster PLUS AL components are protected against corrosion as standard. Corrosion protection meets at least category C2-M requirements to DIN EN ISO 12944-2. Suspension components are galvanized, series track sections are anodized, other components are provided with a painted finish.



### **3.3.13 Ambient conditions**

ProfileMaster PLUS AL installations are designed for operation indoors and for temperatures ranging from -20 °C to +70 °C.

## 4 PROFILEMASTER PLUS AL CLASSIC – PLANNING AND PROJECT DRAFTING

The following sections provide an overview of applications for which AL profile sections can be used:

Suspension crane of single and double-girder design.

### 4.1 Project drafting of suspension crane installations

All information and data necessary for project planning must be collected for planning ProfileMaster PLUS AL installation projects. The project planning sheet in [Project planning sheet for ProfileMaster PLUS AL installations \(page 16\)](#) should be used for this purpose.

**As a basis for planning, a sketch or drawing should be provided** showing a scale representation of the track layout, position of the suspensions and joints and the number of carriers or cranes, branch sections, etc., see [Examples and symbols \(page 14\)](#).

**All installations must be dimensioned in such a way that the end caps and internal buffer stops are not approached during normal operation.**

### 4.2 ProfileMaster PLUS AL product configurator

We recommend you use the ProfileMaster PLUS AL product configurator for planning suspension crane installation projects. Please refer to our homepage at







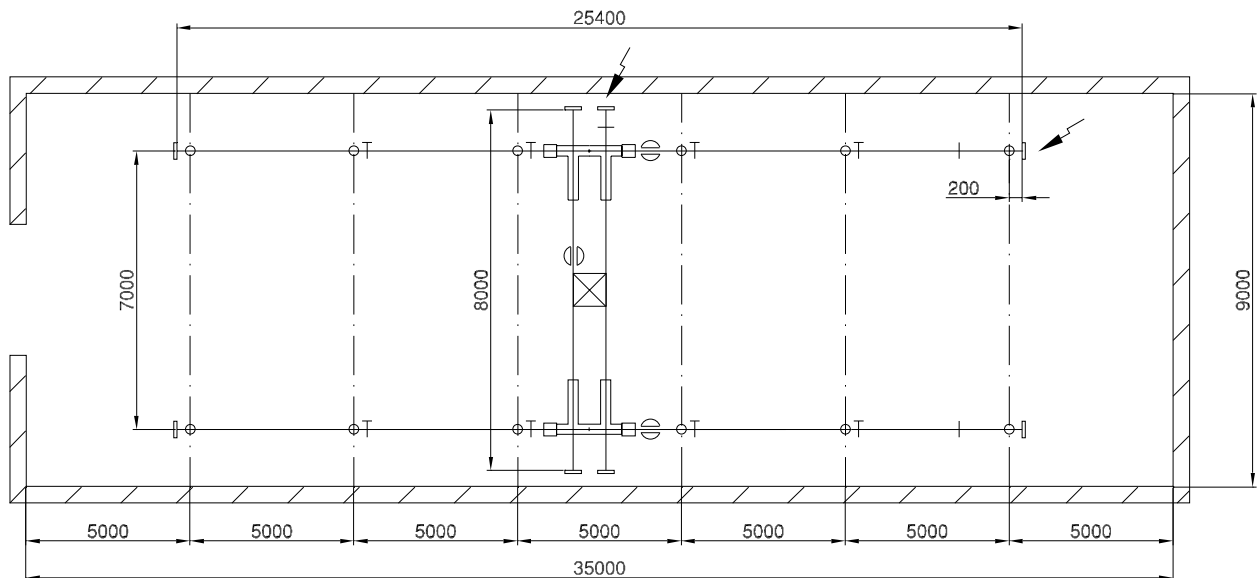



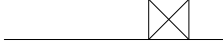
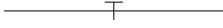

[www.swfkrantechnik.com](http://www.swfkrantechnik.com)

### 4.3 Examples and symbols

#### Double-girder crane

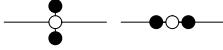
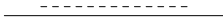
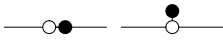
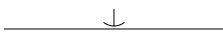

### Symbols for use in drawings

Direction of travel		Rigid crane trolley	
Straight section		Double-rail crab	
Joint bolt set		Travel drive	
Internal buffer stop		Travel drive with limit switch	
Cap with buffer		Limit switch actuator	
Suspension		Powerfeed	
V-type suspension fitting		Power supply	
Stiffener		Current collector	
Trolley			

### 4.4 Project planning sheet for ProfileMaster PLUS AL installations

<b>Customer</b>		Project no.	
		Customer no.	
		Customer	
		Person responsible	Date
		Dept./Sales office	
Stage of customer's planning Financial planning for investments <input type="checkbox"/> Tech. <input type="checkbox"/> Prelim. <input type="checkbox"/> Detailed planning Implementation expected _____ <input type="checkbox"/> Invitation to tender <input type="checkbox"/> Order soon to be placed		<b>Scope of required quotation</b> <input type="checkbox"/> Budget offer  <input type="checkbox"/> Detailed quotation <input type="checkbox"/> with steelwork Quotation deadline _____	
		<input type="checkbox"/> excl. <input type="checkbox"/> with erection	<input type="checkbox"/> incl. sketch Delivery deadline _____
<b>Type of installation</b>			
<input type="checkbox"/> Single-girder crane <input type="checkbox"/> Double-girder crane		AL crane section _____ AL crane section _____	AL track section _____
<b>Technical data</b>			
SWL	_____ kg	Average operating time	_____ hours/day
Track length	_____ m		
Crane length	_____ m	Crane span dimension	_____ m
		Load hook distance for several loads	_____ m
		Highest hook position above floor	_____ m
Installation site _____			
Type of superstructure/suspension methods/flange _____			
Clear height from floor to bottom edge of superstructure _____			
<b>Hoist unit</b>			
Electric chain hoist type _____		Lifting speed v	_____ / _____ m/min
Hook path _____ m			
<b>Travel speeds</b>			
Travelling hoist	<input type="checkbox"/> Manual	<input type="checkbox"/> Electric, v =	_____ / _____ m/min
Crane	<input type="checkbox"/> Manual	<input type="checkbox"/> Electric, v =	_____ / _____ m/min
<b>Power supply</b>			
On the crane	<input type="checkbox"/> Trailing cable	<input type="checkbox"/> Integrated conductor line	<input type="checkbox"/> External conductor line
On the track	<input type="checkbox"/> Trailing cable	<input type="checkbox"/> Integrated conductor line	<input type="checkbox"/> External conductor line
<b>Current type</b>			
Operating voltage _____ V,		_____ HZ	
<b>Type of control</b>			
<input type="checkbox"/> From trolley	<input type="checkbox"/> From crane	<input type="checkbox"/> Mobile	<input type="checkbox"/> Wireless
Additional information (e.g. special ambient conditions)			
Special commercial conditions			

## 4.5 Profile load capacities according to the diagram

The diagram showing the load capacity of the profile sections provides the basis for determining the profile section sizes for cranes and tracks, crane span dimensions  $l_{kr}$  and distances between suspensions  $l_w$ .

The crane span dimension and distances between suspensions which are permitted for the individual crane and track sections can be read off for a given load.

Ensure compliance with the permissible length of overhang, distances of joints from suspension assemblies, and maximum loads on suspension assemblies and trolleys.

(Curves apply if hoists are used with lifting speeds up to 16 m/min. For higher speeds, see [Hoists with ProfileMaster PLUS AL \(page 23\)](#).)

### Selecting the section

Determining the distance between suspensions or crane span dimension:

1. Determine load  $K_{Ges}$  according to [Steps for project planning and technical specification \(page 19\)](#) to [Calculating load GAB on one suspension fitting \(page 20\)](#).
2. Determine the maximum value for  $l_w$  and  $l_{kr}$  in the diagram (where it intersects the limit curve).
3. Select the most suitable profile section.

### Push travel

All profile section sizes

### Suitable for electric travel

All profile section sizes

### Technical values

AL profile section	AL12	AL16	AL18	AL22
Moment of inertia	313 cm <sup>4</sup>	713 cm <sup>4</sup>	1520 cm <sup>4</sup>	2593 cm <sup>4</sup>
Neutral axis	Approx. profile center			

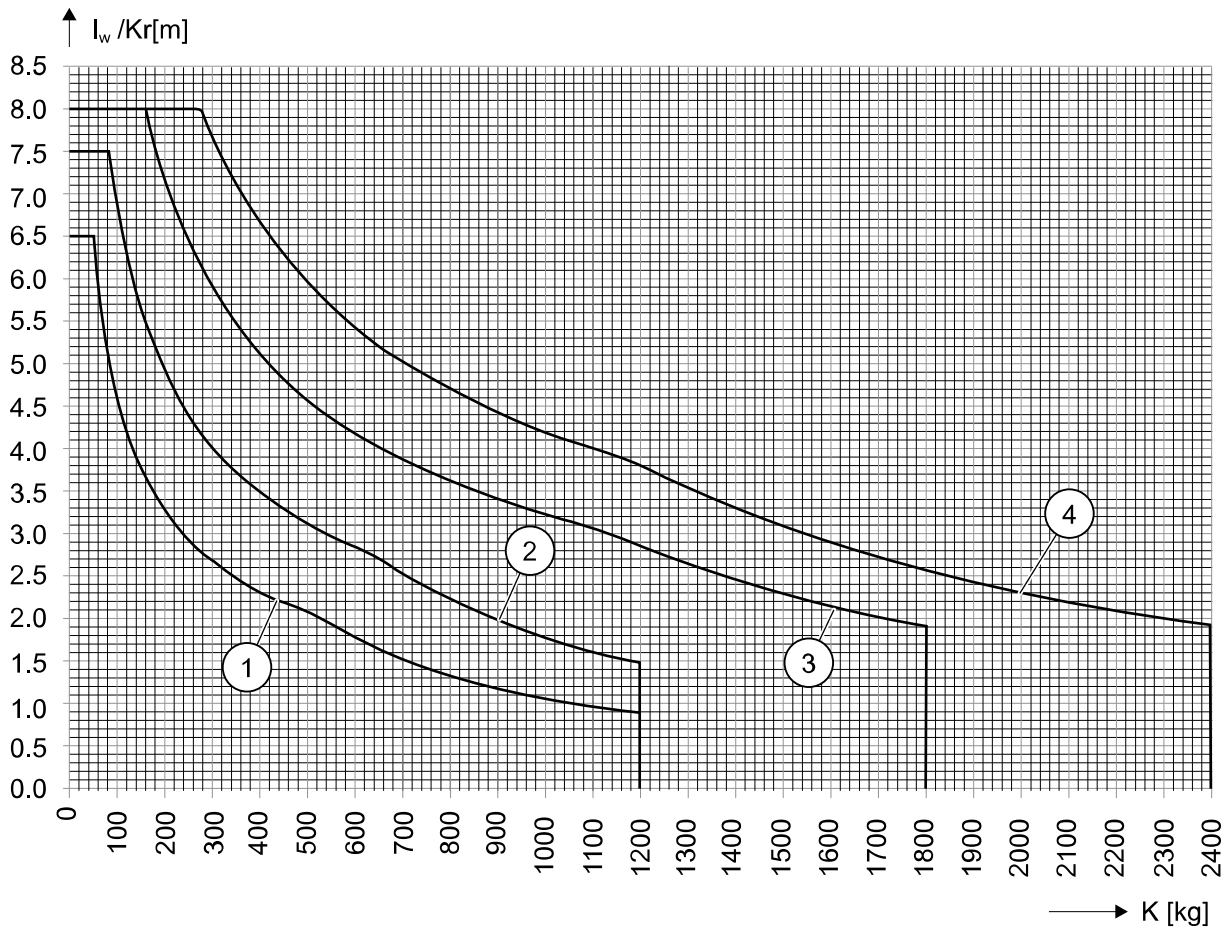

- 1. AL12
- 2. AL16

- 3. AL18
- 4. AL22

K = Load on the profile section  
 $l_w$  = Distance between suspensions  
 $l_{Kr}$  = Crane span dimension

Important: - - - Limit curves for maximum length of straight sections. Pay attention to the distance between supports and distances of joints (see [Calculating load GAB on one suspension fitting \(page 20\)](#)). Lifted load coefficient  $\psi$  and dead load coefficient  $\phi$  to DIN 15018 for crane group H1, B3 as well as the dead load of each loaded girder are already considered in the calculation diagrams.

## 4.6 Steps for project planning and technical specification

### Calculating load K

#### Double-girder crane

The girder with the least favorable load (RF friction-wheel drive) is considered in the following

$$K = 0.5 (GH + G3 + GRFK)$$

#### Crane runway

Load does not travel on overhung portion of crane girder

$$K = GH + G3 + 0.50 (G1 + G2)$$

Load travels on overhung portion of crane girder

$$K = GH + G3 + 0.80 (G1 + G2)$$

#### Where:

GH = SWL including load handling attachment

G1 = Crane girder dead load including fittings

G2 = Dead load of crane trolleys including fittings (both ends together)

G3 = Dead load of trolley including hoist, cross-travel drive and fittings

GRFK = Dead load of cross-travel drive and fittings

## 4.7 Reading off from the diagram

A distinction is made between a concentrated load, two identical loads or more than two identical loads in one panel.

### 4.7.1 Crane span dimension $l_{Kr}$

$e_{Ka}$  = Distance between cross-travel trolleys or wheel axles

### 4.7.2 Distance between suspensions $l_w$

$e_{KT}$  = Distance between crane trolleys or wheel axles

### 4.7.3 Concentrated load

For the (concentrated) load K in the panel between supports, the permissible limit for  $l_w$  or  $l_{Kr}$  can be read off direct from the diagram.

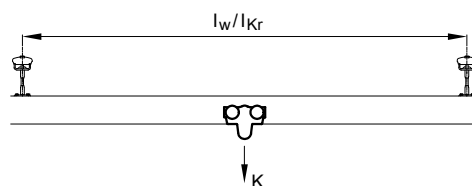

### 4.7.4 Several loads

**For two or more loads at a maintained distance in one panel, the max.  $l_w$  or  $l_{Kr}$  must never exceed the permissible limit for one of the individual loads.**

### 4.7.5 Two identical loads or load bar

By adding both loads, a total load  $K_{Ges}$  is obtained for which the limits  $l_w(K_{Ges})$  or  $l_{Kr}(K_{Ges})$  are taken from the diagram. This limit can be increased using the following formula:

$$\text{max. } l_w = l_w(K_{Ges}) + 0.9 \times e_{Ka} \text{ (or } e_{KT})$$

$$\text{max. } l_{Kr} = l_{Kr}(K_{Ges}) + 0.9 \times e_{Ka} \text{ (or } e_{KT})$$

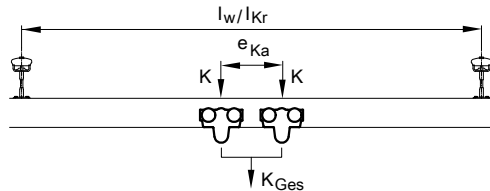

### 4.7.6 More than two identical loads at equal distances

The loads in one panel between supports are added up and a total load  $K_{Ges}$  is obtained, for which the limit  $l_w(K_{Ges})$  is taken from the diagram. This limit can be increased using the following formula:

$$\text{max. } l_w = l_w(K_{Ges}) + n/2 \times e_{Ka} \text{ (or } e_{KT}); n = \text{number of loads } K$$

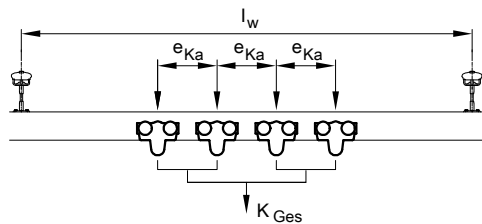

## 4.8 Calculating load $G_{AB}$ on one suspension fitting

The suspension fitting with the worst-case load is considered in the following.

Table 1. Max. permissible load  $G_{AB}$  on one suspension fitting

AL profile section	AL12	AL16	AL18	AL22
max. $G_{AB}$ [kg]	750		1400	1700

### 4.8.1 Concentrated load

The load on one suspension is calculated from value  $K$  for suspension crane tracks and from the proportional track girder dead load.

Proportional track girder dead load = max. distance between suspensions x track girder weight/m x 1.25

$$G_B = \text{Track girder weight/m}; l_w = \text{Max. distance between suspension fittings}$$

$$G_{AB} = K_{Ges} + G_B \times l_w \times 1.25$$

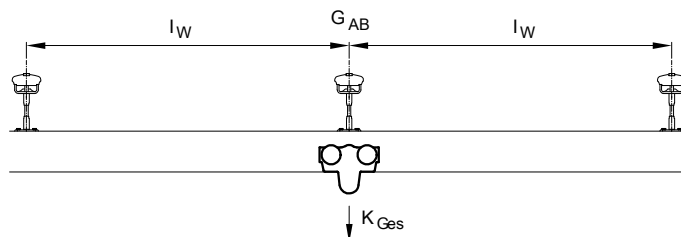



### 4.8.2 Two or more loads in one of the two panels between suspensions

The load on one suspension is determined from the sum total of all concentrated loads in two panels and from the proportional track dead load. If the load on one suspension determined according to this formula exceeds the permissible limit, one or both of the following measures are required:

- Reduce the distance between suspensions by providing additional suspensions
- Distribute the load by spacing loads at a safe distance

$$G_{AB} = K_{Ges} + G_B \times l_w \times 1.25$$

Several identical loads

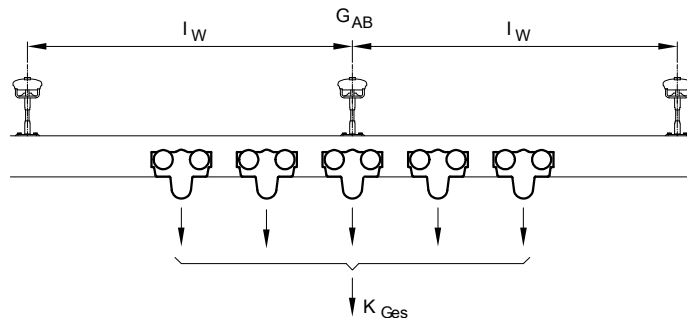

### 4.8.3 Two loads or groups of loads at a distance e\_KT

$$e_{KT} = 0.5 \times l_w : G_{AB} = 0.9K_{Ges} + G_B \times l_w \times 1.25$$

$$e_{KT} = l_w : G_{AB} = 0.7K_{Ges} + G_B \times l_w \times 1.25 \text{ (load distance = distance between suspensions)}$$

$$e_{KT} = 1.5 \times l_w : G_{AB} = 0.5K_{Ges} + G_B \times l_w \times 1.25$$

Identical load groups

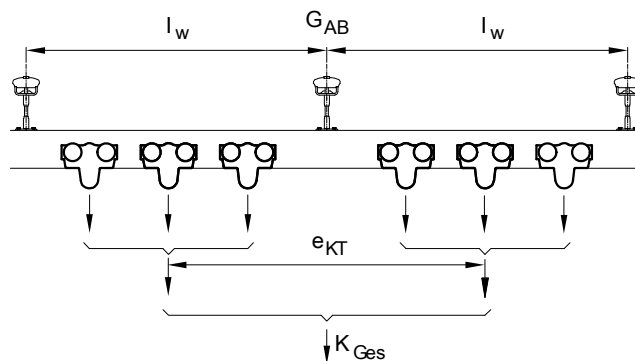

## 4.9 System dimensions and system limits

### 4.9.1 Overhang

			AL12/AL16	AL18/AL22
Shortest possible overhang	$u_{min}$	[mm]	40	50
Project planning values for overhang	$u$	[mm]	200	300

The stability of the track section should be checked for short tracks and crane girders. (Multiply load on overhang by a factor of 1.2, crane girder forms counter-torque).

ProfileMaster PLUS AL tracks and cranes must not be lifted (e.g. where the load is on the overhang).

**If the girder is unstable (girder is lifted, suspension is relieved of load), the suspension is subjected to impact loading which causes wear and can lead to premature failure of the connection.**

### 4.9.2 Crane overhang

The maximum and minimum lengths of overhang for cranes can be found in the crane selection table. They are directly related to the crane girder length.

**The length of overhang  $u$  can be increased for**

- flat cable supply lines by the length of the accumulated cable carriers at the end of the track where they accumulate,
- unloaded spacer trolleys – by the corresponding overall dimension.

The overhang at either end of the crane applicable to double-girder cranes running on more than two crane runway tracks is that shown in the selection table for cranes with the same load capacity and comparable span.

### 4.9.3 Track overhang

Refer to the crane selection tables for the maximum lengths of overhang  $u$  (for single-girder cranes).

### 4.9.4 Approach dimension

Approach dimension  $l_{an}$  (load hook center to girder end) is determined by the dimensions of the individual components.

### 4.9.5 Permissible distance of joint from suspension $st$

A suspension fitting must be provided in the vicinity of each track joint or girder joint on the crane.

			AL12/AL16	AL18/AL22	
<b>Minimum distance</b>	$st_{min}$	[mm]	$l_w \leq 5\text{ m}$	40	50
			$l_w > 5\text{ m}$	0.05 x $l_w$	
<b>Maximum permissible distance</b>	$st_{max}$	[mm]	0.1 x $l_w$		

### 4.9.6 Drive

ProfileMaster PLUS AL single and double-girder cranes can be easily moved by hand. Crabs and rigid cranes can also be fitted with electric drives.

### 4.9.7 Deflection

If the maximum spacing between supports/crane span is selected in the selection diagram, the deflection ratio ranges up to 1/500. Deflection can be reduced by the use of larger ProfileMaster PLUS AL or steel profile sections.

## 4.10 Hoists with ProfileMaster PLUS AL

### Higher lifting speeds

The layout diagrams shown in ProfileMaster PLUS AL guides apply for SWF chain hoists with lifting speeds up to max. 16 m/min.

The use of other chain hoists can in result in an overload of the crane installation in borderline cases. Higher lifting speeds and weights can be considered by means of the following factor using the diagrams:

$$G_{Hnew} = G_H \times (0.97 + 0.002 \times v_H)$$

$v_H$  = lifting speed in m/min

## 4.11 Single and double-girder cranes

### 4.11.1 Single-girder crane

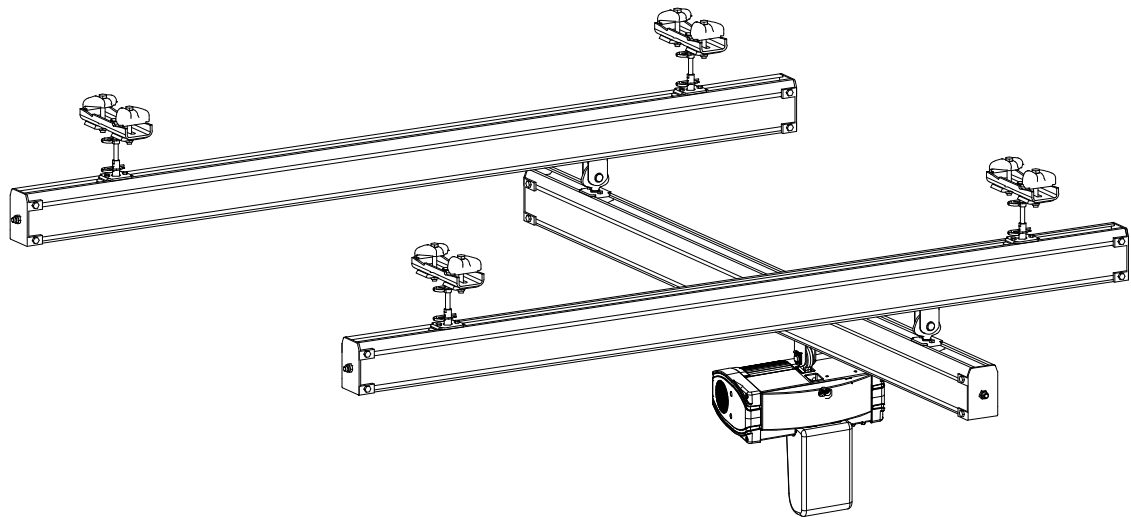

Single-girder crane		
Assemblies	Components	See chapter/section
Rail elements	Rail, joint bolt set, end cap, buffer, internal buffer stop, information plates	<a href="#">Crane runway and crane girder basic components (page 38)</a>
Suspension	Suspension, short suspension, upper suspension bracket, upper suspension clamp, ball-head suspension rod, suspension rod, ball-head bolt, track suspension clamp, spring clip	<a href="#">Track suspension (page 45)</a>
Trolley combination	Trolley, articulated frame, load bar, crane trolley assembly, crane suspension eye, rigid crane end carriage	<a href="#">Trolley combinations (page 64)</a>
Travel drive	RF 125	<a href="#">Travel drives for crabs and cranes (page 72)</a>
Link bars	Trolley link, link bar, spacer bar	<a href="#">Coupling elements and spacer bars (page 78)</a>
Accessories	Buffers on crabs and cranes	<a href="#">Buffers and end stops (page 82)</a>
Elec. power supply	Cable slider, cable trolley, trailing cable, conductor line	<a href="#">Power supply to crabs and cranes (page 84)</a>
Control system		<a href="#">ProfileMaster PLUS AL standard electric equipment (page 92)</a>

#### Execution:

- a) Articulated track and crane suspensions (shown)
  - b) Articulated track suspensions with rigid crane trolleys
- Crane girder without a rail joint

### 4.11.2 Double-girder crane

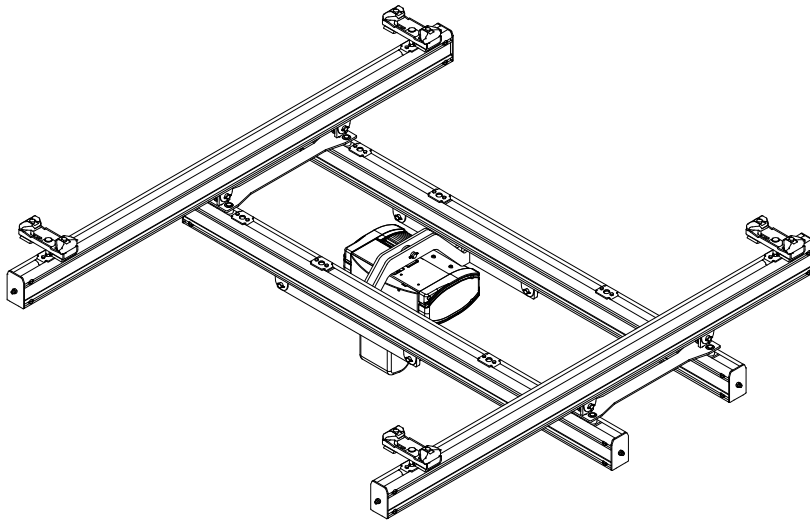

Double-girder crane		
Assemblies	Components	See chapter/section
Rail elements	Rail, joint bolt set, end cap, buffer, internal buffer stop, information plates	<a href="#">Crane runway and crane girder basic components (page 38)</a>
Suspension	Short suspension, upper suspension bracket, upper suspension clamp, ball-head suspension rod, suspension rod, track suspension clamp, spring clip	<a href="#">Track suspension (page 45)</a>
Trolley combination	Trolley, articulated frame, frame for double-girder crane, crab frame	<a href="#">Trolley combinations (page 64)</a>
Travel drive	RF 125	<a href="#">Travel drives for crabs and cranes (page 72)</a>
Link bars	Trolley link, link bar, spacer bar	<a href="#">Coupling elements and spacer bars (page 78)</a>
Accessories	Buffers on crabs and cranes	<a href="#">Buffers and end stops (page 82)</a>
Elec. power supply	Cable slider, cable trolley, trailing cable, conductor line	<a href="#">Power supply to crabs and cranes (page 84)</a>
Control system		<a href="#">ProfileMaster PLUS AL standard electric equipment (page 92)</a>

**Execution:**

articulated track suspensions with rigid crane trolleys  
 (Articulated crane suspensions are not used).

### 4.11.3 Specifying single and double-girder cranes according to selection tables

Single-girder crane

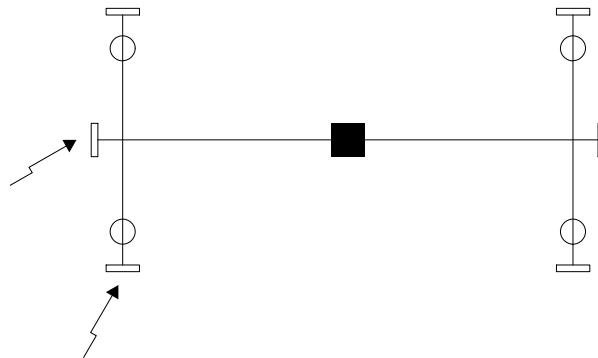
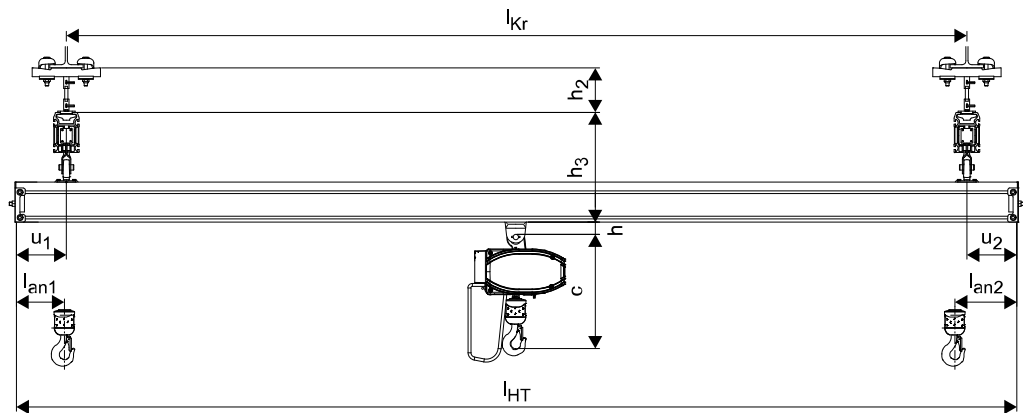

Double-girder crane

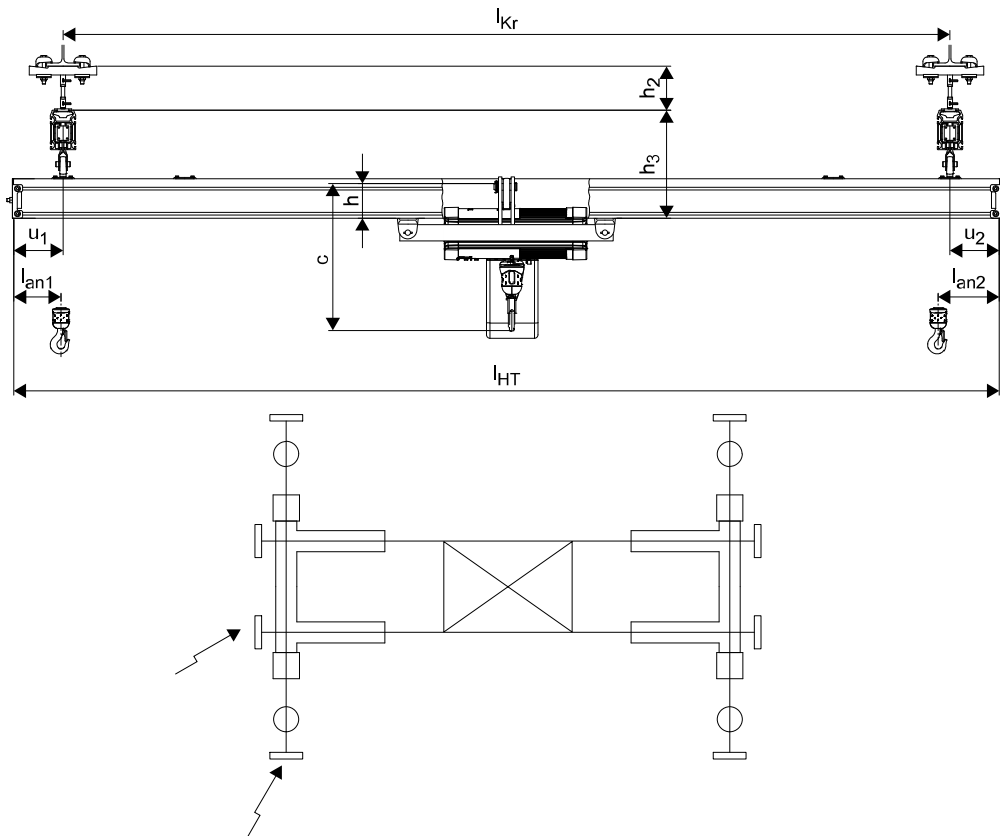

- $l_{Kr}$  = Crane span dimension
- $h$  = Bottom edge of rail to top edge of pin
- $c$  = Hoist headroom dimension
- $l_{HT}$  = Crane girder length
- $h_2$  = Bottom edge of I-beam to top edge of track girder
- $l_{an}$  = Approach dimension
- $u$  = Overhang
- $h_3$  = Top edge of track girder to bottom edge of crane girder

The following selection tables show a few of the many possible combinations for building crane installations with ProfileMaster PLUS AL. Use ProfileMaster PLUS AL Designer for precise specification of installations.

$l_w$  data apply to one crane on the crane runway.

Crane girder overhangs are always the same on both sides of the crane.

Deflection limits: cranes, tracks: 1/500,

frequency  $\geq 2.8$  Hz

**Where there are several cranes on the same crane runway, the crane trolley assemblies of single-girder cranes must always be designed as double or quadruple trolleys.**

Distances between suspensions  $l_w$  must then be calculated separately. Intermediate lengths for crane girders are possible. Data calculated on the basis of cranes of standard design for standard components and without special fittings.

Check suspension loads.

**Classification based on DIN 15018, H1 B3**

$l_{HT}$  = Crane girder length

$l_{Kr}$  = Crane span dimension

$l_w$  = Distance between track suspensions

Suspension loads on request

All dimensions in m

**Load capacity: 63 kg, hoist weight: 30 kg, max. lifting speed: 30 m/min**

	Profile	$l_{HT}$	Single-girder crane						Double-girder crane					
			$l_{Kr}$		$l_w$				$l_{Kr}$		$l_w$			
			Min.	Max.	AL12	AL16	AL18	AL22	Min.	Max.	AL12	AL16	AL18	AL22
Crane girder section, crane girder length	AL12	1	0.75	- 0.90	4.45	6.65	8.00	8.90	-	-	-	-	-	-
		2	1.65	- 1.90	4.30	6.45	8.00	8.90	1.50	- 1.90	3.90	5.85	8.00	8.90
		3	2.45	- 2.90	4.25	6.35	8.00	8.90	2.05	- 2.90	3.80	5.65	8.00	8.90
		4	3.25	- 3.90	4.15	6.20	8.00	8.90	2.70	- 3.90	3.65	5.50	7.85	8.90
		5	3.95	- 4.50	4.05	6.10	8.00	8.90	3.25	- 4.90	3.55	5.35	7.65	8.90
		6	-	-	-	-	-	-	3.80	- 5.90	3.40	5.05	7.20	8.90
		7	-	-	-	-	-	-	4.45	- 6.00	3.35	4.95	7.10	8.90
		8	-	-	-	-	-	-	5.75	- 6.00	3.35	5.00	7.15	8.90
	AL16	1	0.75	- 0.90	4.40	6.60	8.00	8.90	-	-	-	-	-	-
		2	1.60	- 1.90	4.25	6.35	8.00	8.90	1.50	- 1.90	3.80	5.70	8.00	8.90
		3	2.40	- 2.90	4.15	6.20	8.00	8.90	1.95	- 2.90	3.70	5.50	7.90	8.90
		4	3.10	- 3.90	4.05	6.05	8.00	8.90	2.50	- 3.90	3.55	5.30	7.60	8.90
		5	3.75	- 4.90	3.95	5.90	8.00	8.90	3.05	- 4.90	3.45	5.10	7.35	8.90
		6	4.35	- 5.90	3.85	5.80	8.00	8.90	3.45	- 5.90	3.25	4.80	6.90	8.90
		7	4.90	- 6.80	3.80	5.65	8.00	8.90	3.85	- 6.90	3.15	4.70	6.70	8.75
		8	5.85	- 6.85	3.80	5.65	8.00	8.90	4.60	- 7.50	3.15	4.65	6.65	8.70
	AL18	1	-	-	-	-	-	-	-	-	-	-	-	-
		2	1.55	- 1.90	4.15	6.20	8.00	8.90	1.50	- 1.90	3.60	5.35	7.65	8.90
		3	2.25	- 2.90	4.00	5.95	8.00	8.90	1.55	- 2.90	3.30	4.95	7.05	8.90
		4	2.85	- 3.90	3.85	5.75	8.00	8.90	2.05	- 3.90	3.20	4.70	6.75	8.80
		5	3.40	- 4.90	3.75	5.60	8.00	8.90	2.55	- 4.90	3.05	4.55	6.50	8.50
		6	3.90	- 5.90	3.65	5.40	7.90	8.90	3.00	- 5.90	2.95	4.30	6.15	8.05
		7	4.35	- 6.90	3.55	5.25	7.70	8.90	3.50	- 6.90	2.85	4.25	6.05	7.85
		8	5.00	- 7.90	3.50	5.20	7.60	8.90	4.00	- 7.90	2.80	4.15	5.90	7.70
AL22	1	-	-	-	-	-	-	-	-	-	-	-	-	
	2	1.50	- 1.90	4.10	6.10	8.00	8.90	1.50	- 1.90	3.55	5.25	7.55	8.90	
	3	2.20	- 2.90	3.90	5.85	8.00	8.90	1.50	- 2.90	3.30	4.85	6.95	8.90	
	4	2.75	- 3.90	3.80	5.65	8.00	8.90	2.00	- 3.90	3.15	4.65	6.65	8.65	
	5	3.25	- 4.90	3.65	5.45	7.95	8.90	2.50	- 4.90	3.00	4.45	6.40	8.35	
	6	3.70	- 5.90	3.55	5.30	7.70	8.90	3.00	- 5.90	2.90	4.25	6.05	7.90	
	7	4.10	- 6.90	3.45	5.10	7.45	8.90	3.50	- 6.90	2.80	4.15	5.90	7.70	
	8	5.00	- 7.90	3.40	5.10	7.45	8.90	4.00	- 7.90	2.75	4.05	5.80	7.50	

**Load capacity: 125 kg, hoist weight: 30 kg, max. lifting speed: 30 m/min**

	Profile	I <sub>HT</sub>	Single-girder crane						Double-girder crane					
			I <sub>Kr</sub>		I <sub>w</sub>				I <sub>Kr</sub>		I <sub>w</sub>			
			Min.	Max.	AL12	AL16	AL18	AL22	Min.	Max.	AL12	AL16	AL18	AL22
Crane girder section, crane girder length	AL12	1	0.75	- 0.90	3.55	5.30	7.70	8.90	-	-	-	-	-	-
		2	1.70	- 1.90	3.50	5.20	7.60	8.90	1.50	- 1.90	3.30	4.90	7.05	8.90
		3	2.60	- 2.90	3.45	5.15	7.50	8.90	2.20	- 2.90	3.20	4.80	6.90	8.90
		4	3.40	- 3.55	3.40	5.05	7.40	8.90	2.95	- 3.90	3.15	4.70	6.75	8.80
		5	-	-	-	-	-	-	3.60	- 4.85	3.10	4.60	6.60	8.60
		6	-	-	-	-	-	-	4.25	- 4.85	2.95	4.40	6.30	8.20
		7	-	-	-	-	-	-	-	-	-	-	-	-
		8	-	-	-	-	-	-	-	-	-	-	-	-
	AL16	1	0.75	- 0.90	3.55	5.25	7.70	8.90	-	-	-	-	-	-
		2	1.65	- 1.90	3.45	5.15	7.55	8.90	1.50	- 1.90	3.25	4.85	6.95	8.90
		3	2.55	- 2.90	3.40	5.05	7.40	8.90	2.10	- 2.90	3.15	4.70	6.75	8.80
		4	3.35	- 3.90	3.35	5.00	7.30	8.90	2.80	- 3.90	3.05	4.55	6.55	8.55
		5	4.10	- 4.90	3.30	4.90	7.15	8.90	3.40	- 4.90	3.00	4.45	6.40	8.35
		6	4.80	- 5.40	3.25	4.85	7.05	8.90	4.00	- 5.90	2.90	4.25	6.10	7.95
		7	-	-	-	-	-	-	4.50	- 6.90	2.80	4.15	5.95	7.75
		8	-	-	-	-	-	-	4.95	- 7.35	2.75	4.10	5.85	7.60
	AL18	1	-	-	-	-	-	-	-	-	-	-	-	-
		2	1.65	- 1.90	3.40	5.05	7.40	8.90	1.50	- 1.90	3.10	4.60	6.55	8.55
		3	2.45	- 2.90	3.30	4.95	7.20	8.90	1.65	- 2.90	2.95	4.35	6.20	8.10
		4	3.15	- 3.90	3.25	4.80	7.05	8.90	2.30	- 3.90	2.85	4.20	6.00	7.85
		5	3.80	- 4.90	3.15	4.70	6.90	8.90	2.85	- 4.90	2.75	4.10	5.80	7.60
		6	4.45	- 5.90	3.10	4.60	6.75	8.80	3.35	- 5.90	2.65	3.90	5.55	7.25
		7	5.00	- 6.90	3.05	4.50	6.60	8.65	3.80	- 6.90	2.60	3.80	5.40	7.05
		8	5.55	- 7.85	2.95	4.45	6.45	8.45	4.20	- 7.90	2.55	3.70	5.25	6.85
AL22	1	-	-	-	-	-	-	-	-	-	-	-	-	
	2	1.60	- 1.90	3.35	5.00	7.30	8.90	1.50	- 1.90	3.05	4.55	6.50	8.50	
	3	2.40	- 2.90	3.25	4.90	7.10	8.90	1.60	- 2.90	2.90	4.25	6.10	7.95	
	4	3.10	- 3.90	3.20	4.75	6.95	8.90	2.20	- 3.90	2.80	4.10	5.90	7.65	
	5	3.70	- 4.90	3.10	4.65	6.75	8.85	2.75	- 4.90	2.70	4.00	5.70	7.40	
	6	4.30	- 5.90	3.05	4.55	6.60	8.65	3.20	- 5.90	2.60	3.80	5.40	7.05	
	7	4.80	- 6.90	2.95	4.40	6.45	8.45	3.60	- 6.90	2.50	3.70	5.25	6.85	
	8	5.30	- 7.90	2.90	4.35	6.30	8.25	4.00	- 7.90	2.45	3.60	5.15	6.70	



Load capacity: 160 kg, hoist weight: 35 kg, max. lifting speed: 20 m/min

	Profile	I <sub>HT</sub>	Single-girder crane						Double-girder crane					
			I <sub>Kr</sub>		I <sub>w</sub>				I <sub>Kr</sub>		I <sub>w</sub>			
			Min.	Max.	AL12	AL16	AL18	AL22	Min.	Max.	AL12	AL16	AL18	AL22
Crane girder section, crane girder length	AL12	1	0.75	- 0.90	3.20	4.75	6.95	8.90	-	-	-	-	-	-
		2	1.70	- 1.90	3.15	4.70	6.85	8.90	1.50	- 1.90	3.05	4.50	6.45	8.40
		3	2.60	- 2.90	3.10	4.65	6.80	8.85	2.25	- 2.90	2.95	4.40	6.35	8.25
		4	-	-	-	-	-	-	3.00	- 3.90	2.90	4.35	6.20	8.10
		5	-	-	-	-	-	-	3.75	- 4.40	2.85	4.25	6.10	7.95
		6	-	-	-	-	-	-	-	-	-	-	-	-
	AL16	1	0.75	- 0.90	3.20	4.75	6.90	8.90	-	-	-	-	-	-
		2	1.70	- 1.90	3.15	4.65	6.80	8.90	1.50	- 1.90	3.00	4.45	6.35	8.30
		3	2.55	- 2.90	3.10	4.60	6.70	8.80	2.15	- 2.90	2.90	4.35	6.20	8.10
		4	3.40	- 3.90	3.05	4.55	6.65	8.65	2.90	- 3.90	2.85	4.25	6.10	7.95
		5	4.20	- 4.85	3.00	4.50	6.55	8.55	3.55	- 4.90	2.80	4.15	5.95	7.75
		6	-	-	-	-	-	-	4.20	- 5.90	2.70	4.00	5.70	7.45
		7	-	-	-	-	-	-	4.75	- 6.65	2.65	3.90	5.60	7.30
		8	-	-	-	-	-	-	5.40	- 6.65	2.60	3.85	5.50	7.20
	AL18	1	-	-	-	-	-	-	-	-	-	-	-	-
		2	1.65	- 1.90	3.10	4.60	6.70	8.75	1.50	- 1.90	2.85	4.25	6.05	7.90
		3	2.50	- 2.90	3.00	4.50	6.55	8.60	1.75	- 2.90	2.75	4.05	5.80	7.55
		4	3.25	- 3.90	2.95	4.40	6.45	8.40	2.40	- 3.90	2.70	3.95	5.65	7.35
		5	4.00	- 4.90	2.90	4.35	6.30	8.25	3.00	- 4.90	2.60	3.85	5.50	7.15
		6	4.65	- 5.90	2.85	4.25	6.20	8.10	3.55	- 5.90	2.50	3.70	5.25	6.85
		7	5.30	- 6.90	2.80	4.20	6.10	8.00	4.05	- 6.90	2.45	3.60	5.15	6.70
		8	5.85	- 7.05	2.75	4.10	6.00	7.85	4.50	- 7.90	2.40	3.55	5.00	6.55
	AL22	1	-	-	-	-	-	-	-	-	-	-	-	-
		2	1.65	- 1.90	3.05	4.55	6.65	8.70	1.50	- 1.90	2.85	4.20	6.00	7.85
3		2.45	- 2.90	3.00	4.45	6.50	8.50	1.70	- 2.90	2.70	4.00	5.70	7.45	
4		3.20	- 3.90	2.95	4.35	6.35	8.30	2.35	- 3.90	2.65	3.90	5.55	7.20	
5		3.90	- 4.90	2.85	4.25	6.25	8.15	2.90	- 4.90	2.55	3.75	5.35	7.00	
6		4.50	- 5.90	2.80	4.20	6.10	8.00	3.40	- 5.90	2.45	3.60	5.15	6.70	
7		5.10	- 6.90	2.75	4.10	6.00	7.85	3.85	- 6.90	2.40	3.50	5.00	6.50	
8		5.65	- 7.90	2.70	4.05	5.90	7.70	4.30	- 7.90	2.35	3.45	4.90	6.35	

**Load capacity: 250 kg, hoist weight: 35 kg, max. lifting speed: 20 m/min**

	Profile	I <sub>HT</sub>	Single-girder crane						Double-girder crane					
			I <sub>Kr</sub>		I <sub>w</sub>				I <sub>Kr</sub>		I <sub>w</sub>			
			Min.	Max.	AL12	AL16	AL18	AL22	Min.	Max.	AL12	AL16	AL18	AL22
Crane girder section, crane girder length	AL12	1	0.80	- 0.90	2.70 <sup>1)</sup>	4.00 <sup>1)</sup>	5.80	7.60	-	-	-	-	-	-
		2	1.75	- 1.90	2.65 <sup>1)</sup>	3.95 <sup>1)</sup>	5.80	7.55	1.50	- 1.90	2.60	3.85	5.55	7.20
		3	-	-	-	-	-	-	2.30	- 2.90	2.60	3.80	5.45	7.10
		4	-	-	-	-	-	-	3.15	- 3.70	2.55	3.75	5.40	7.00
		5	-	-	-	-	-	-	-	-	-	-	-	-
		6	-	-	-	-	-	-	-	-	-	-	-	-
	AL16	1	0.80	- 0.90	2.65 <sup>1)</sup>	3.95 <sup>1)</sup>	5.80	7.60	-	-	-	-	-	-
		2	1.70	- 1.90	2.65 <sup>1)</sup>	3.90 <sup>1)</sup>	5.75	7.50	1.50	- 1.90	2.60	3.85	5.50	7.15
		3	2.65	- 2.90	2.60 <sup>1)</sup>	3.90 <sup>1)</sup>	5.70	7.45	2.25	- 2.90	2.55	3.75	5.40	7.05
		4	3.50	- 3.90	2.60 <sup>1)</sup>	3.85 <sup>1)</sup>	5.65	7.35	3.05	- 3.90	2.50	3.70	5.30	6.90
		5	-	-	-	-	-	-	3.80	- 4.90	2.45	3.65	5.20	6.80
		6	-	-	-	-	-	-	4.50	- 5.60	2.40	3.55	5.05	6.60
		7	-	-	-	-	-	-	5.15	- 5.60	2.35	3.50	4.95	6.50
		8	-	-	-	-	-	-	-	-	-	-	-	-
	AL18	1	-	-	-	-	-	-	-	-	-	-	-	-
		2	1.70	- 1.90	2.60 <sup>1)</sup>	3.90 <sup>1)</sup>	5.70	7.45	1.50	- 1.90	2.50	3.70	5.25	6.85
		3	2.60	- 2.90	2.60 <sup>1)</sup>	3.85 <sup>1)</sup>	5.60	7.30	1.80	- 2.90	2.45	3.60	5.10	6.65
		4	3.40	- 3.90	2.55 <sup>1)</sup>	3.75 <sup>1)</sup>	5.50	7.20	2.55	- 3.90	2.40	3.50	5.00	6.50
		5	4.20	- 4.90	2.50 <sup>1)</sup>	3.70 <sup>1)</sup>	5.45	7.10	3.25	- 4.90	2.35	3.45	4.90	6.35
		6	4.95	- 5.90	2.50 <sup>1)</sup>	3.65 <sup>1)</sup>	5.35	7.00	3.90	- 5.90	2.30	3.35	4.75	6.15
		7	5.65	- 5.90	2.45 <sup>1)</sup>	3.60 <sup>1)</sup>	5.30	6.95	4.45	- 6.90	2.25	3.30	4.65	6.05
		8	-	-	-	-	-	-	5.00	- 7.90	2.20	3.20	4.55	5.95
	AL22	1	-	-	-	-	-	-	-	-	-	-	-	-
		2	1.70	- 1.90	2.60 <sup>1)</sup>	3.85 <sup>1)</sup>	5.65	7.40	1.50	- 1.90	2.50	3.70	5.25	6.85
3		2.55	- 2.90	2.55 <sup>1)</sup>	3.80 <sup>1)</sup>	5.55	7.25	1.80	- 2.90	2.45	3.55	5.05	6.60	
4		3.35	- 3.90	2.50 <sup>1)</sup>	3.75 <sup>1)</sup>	5.45	7.15	2.50	- 3.90	2.35	3.45	4.95	6.40	
5		4.10	- 4.90	2.50 <sup>1)</sup>	3.70 <sup>1)</sup>	5.40	7.05	3.15	- 4.90	2.30	3.40	4.80	6.25	
6		4.85	- 5.90	2.45 <sup>1)</sup>	3.65 <sup>1)</sup>	5.30	6.95	3.75	- 5.90	2.25	3.30	4.65	6.05	
7		5.50	- 6.90	2.40 <sup>1)</sup>	3.55 <sup>1)</sup>	5.20	6.85	4.30	- 6.90	2.20	3.20	4.55	5.90	
8		6.15	- 7.70	2.40 <sup>1)</sup>	3.50 <sup>1)</sup>	5.15	6.75	4.80	- 7.90	2.15	3.15	4.45	5.80	

<sup>1)</sup> Two trolleys on each end of crane

Load capacity: 320 kg, hoist weight: 55 kg, max. lifting speed: 15 m/min

	Profile	I <sub>HT</sub>	Single-girder crane						Double-girder crane					
			I <sub>Kr</sub>		I <sub>w</sub>				I <sub>Kr</sub>		I <sub>w</sub>			
			Min.	Max.	AL12	AL16	AL18	AL22	Min.	Max.	AL12	AL16	AL18	AL22
Crane girder section, crane girder length	AL12	1	0.75	- 0.90 <sup>2)</sup>	2.50 <sup>1)</sup>	3.75 <sup>1)</sup>	5.45	7.15	-	-	-	-	-	-
		2	1.55	- 1.90 <sup>2)</sup>	2.35 <sup>1)</sup>	3.45 <sup>1)</sup>	5.05	6.60	1.50	- 1.90	2.35	3.45	4.95	6.45
		3	-	-	-	-	-	-	2.35	- 2.90	2.30	3.40	4.90	6.35
		4	-	-	-	-	-	-	3.20	- 3.25	2.30	3.40	4.85	6.30
		5	-	-	-	-	-	-	-	-	-	-	-	-
		6	-	-	-	-	-	-	-	-	-	-	-	-
	AL16	1	0.75	- 0.90 <sup>2)</sup>	2.50 <sup>1)</sup>	3.75 <sup>1)</sup>	5.45	7.15	-	-	-	-	-	-
		2	1.55	- 1.90 <sup>2)</sup>	2.35 <sup>1)</sup>	3.45 <sup>1)</sup>	5.05	6.60	1.50	- 1.90	2.35	3.45	4.90	6.40
		3	2.45	- 2.90 <sup>2)</sup>	2.30 <sup>1)</sup>	3.40 <sup>1)</sup>	5.00	6.55	2.30	- 2.90	2.30	3.40	4.85	6.30
		4	3.40	- 3.55 <sup>2)</sup>	2.30 <sup>1)</sup>	3.40 <sup>1)</sup>	4.95	6.50	3.15	- 3.90	2.25	3.35	4.75	6.20
		5	-	-	-	-	-	-	3.95	- 4.90	2.25	3.30	4.70	6.10
		6	-	-	-	-	-	-	4.70	- 4.90	2.20	3.20	4.60	5.95
		7	-	-	-	-	-	-	-	-	-	-	-	-
		8	-	-	-	-	-	-	-	-	-	-	-	-
	AL18	1	-	-	-	-	-	-	-	-	-	-	-	-
		2	1.75	- 1.90	2.30 <sup>1)</sup>	3.45 <sup>1)</sup>	5.00	6.55	1.50	- 1.90	2.30	3.35	4.75	6.15
		3	2.65	- 2.90	2.30 <sup>1)</sup>	3.40 <sup>1)</sup>	4.95	6.50	1.85	- 2.90	2.25	3.25	4.65	6.05
		4	3.50	- 3.90	2.25 <sup>1)</sup>	3.35 <sup>1)</sup>	4.90	6.40	2.65	- 3.90	2.20	3.20	4.55	5.90
		5	4.30	- 4.90	2.25 <sup>1)</sup>	3.30 <sup>1)</sup>	4.85	6.35	3.40	- 4.90	2.15	3.15	4.45	5.80
		6	5.10	- 5.15	2.20 <sup>1)</sup>	3.30 <sup>1)</sup>	4.80	6.25	4.10	- 5.90	2.10	3.10	4.35	5.65
		7	-	-	-	-	-	-	4.75	- 6.90	2.10	3.05	4.30	5.55
		8	-	-	-	-	-	-	5.35	- 7.05	2.05 <sup>3)</sup>	3.00 <sup>3)</sup>	4.20	5.45
	AL22	1	-	-	-	-	-	-	-	-	-	-	-	-
		2	1.70	- 1.90	2.30 <sup>1)</sup>	3.40 <sup>1)</sup>	5.00	6.55	1.50	- 1.90	2.30	3.30	4.70	6.15
3		2.60	- 2.90	2.30 <sup>1)</sup>	3.35 <sup>1)</sup>	4.95	6.45	1.85	- 2.90	2.20	3.25	4.60	5.95	
4		3.45	- 3.90	2.25 <sup>1)</sup>	3.35 <sup>1)</sup>	4.85	6.35	2.60	- 3.90	2.20	3.15	4.50	5.85	
5		4.25	- 4.90	2.20 <sup>1)</sup>	3.30 <sup>1)</sup>	4.80	6.30	3.30	- 4.90	2.15	3.10	4.40	5.75	
6		5.05	- 5.90	2.20 <sup>1)</sup>	3.25 <sup>1)</sup>	4.75	6.20	4.00	- 5.90	2.10	3.05	4.30	5.55	
7		5.75	- 6.75	2.15 <sup>1)</sup>	3.20 <sup>1)</sup>	4.70	6.15	4.60	- 6.90	2.05 <sup>3)</sup>	3.00 <sup>3)</sup>	4.20	5.45	
8		6.50	- 6.75	2.15 <sup>1)</sup>	3.15 <sup>1)</sup>	4.65	6.05	5.15	- 7.90	2.05 <sup>3)</sup>	2.95 <sup>3)</sup>	4.15	5.35	

<sup>1)</sup> Two trolleys on each end of crane

<sup>2)</sup> Double trolley unit

<sup>3)</sup> Quadruple trolley on each end of crane

Load capacity: 500 kg, hoist weight: 55 kg, max. lifting speed: 15 m/min

	Profile	I <sub>HT</sub>	Single-girder crane						Double-girder crane					
			I <sub>Kr</sub>		I <sub>w</sub>				I <sub>Kr</sub>		I <sub>w</sub>			
			Min.	Max.	AL12	AL16	AL18	AL22	Min.	Max.	AL12	AL16	AL18	AL22
Crane girder section, crane girder length	AL12	1	0.75	- 0.90 <sup>2)</sup>	2.10 <sup>1)</sup>	3.10 <sup>1)</sup>	4.55	5.90	-	-	-	-	-	-
		2	1.55	- 1.90 <sup>2)</sup>	1.95 <sup>1)</sup>	2.90 <sup>1)</sup>	4.20	5.50	1.50	- 1.90	2.00 <sup>3)</sup>	2.90 <sup>3)</sup>	4.15	5.40
		3	-	-	-	-	-	-	2.40	- 2.70	2.00 <sup>3)</sup>	2.90 <sup>3)</sup>	4.10	5.35
		4	-	-	-	-	-	-	-	-	-	-	-	-
	AL16	1	0.75	- 0.90 <sup>2)</sup>	2.10 <sup>1)</sup>	3.10 <sup>1)</sup>	4.50	5.90	-	-	-	-	-	-
		2	1.55	- 1.90 <sup>2)</sup>	1.95 <sup>1)</sup>	2.85 <sup>1)</sup>	4.20	5.50	1.50	- 1.90	2.00 <sup>3)</sup>	2.90 <sup>3)</sup>	4.15	5.40
		3	2.50	- 2.90 <sup>2)</sup>	1.95 <sup>1)</sup>	2.85 <sup>1)</sup>	4.15	5.45	2.35	- 2.90	2.00 <sup>3)</sup>	2.90 <sup>3)</sup>	4.10	5.30
		4	-	-	-	-	-	-	3.25	- 3.90	1.95 <sup>3)</sup>	2.85 <sup>3)</sup>	4.05	5.25
		5	-	-	-	-	-	-	-	-	-	-	-	-
		6	-	-	-	-	-	-	-	-	-	-	-	-
	AL18	1	-	-	-	-	-	-	-	-	-	-	-	-
		2	1.75	- 1.90	1.95 <sup>1)</sup>	2.85 <sup>1)</sup>	4.15	5.45	1.50	- 1.90	2.00 <sup>3)</sup>	2.85 <sup>3)</sup>	4.05	5.25
		3	2.70	- 2.90	1.95 <sup>1)</sup>	2.85 <sup>1)</sup>	4.15	5.40	1.95	- 2.90	1.95 <sup>3)</sup>	2.80 <sup>3)</sup>	4.00	5.15
		4	3.60	- 3.90	2.00 <sup>1)</sup>	2.90 <sup>1)</sup>	4.10	5.35	2.80	- 3.90	1.95 <sup>3)</sup>	2.80 <sup>3)</sup>	3.95	5.10
		5	-	-	-	-	-	-	3.60	- 4.90	1.90 <sup>3)</sup>	2.75 <sup>3)</sup>	3.90	5.05
		6	-	-	-	-	-	-	4.35	- 5.90	1.90 <sup>3)</sup>	2.40 <sup>3)</sup>	3.80	4.95
		7	-	-	-	-	-	-	5.10	- 5.90	1.85 <sup>3)</sup>	1.90 <sup>3)</sup>	3.75	4.85
		8	-	-	-	-	-	-	5.80	- 5.90	1.65 <sup>3)</sup>	1.60 <sup>3)</sup>	3.70	4.80
	AL22	1	-	-	-	-	-	-	-	-	-	-	-	-
		2	1.75	- 1.90	1.95 <sup>1)</sup>	2.85 <sup>1)</sup>	4.15	5.45	1.50	- 1.90	2.00 <sup>3)</sup>	2.85 <sup>3)</sup>	4.00	5.20
		3	2.65	- 2.90	2.00 <sup>1)</sup>	2.90 <sup>1)</sup>	4.10	5.40	1.90	- 2.90	1.95 <sup>3)</sup>	2.80 <sup>3)</sup>	3.95	5.15
		4	3.55	- 3.90	2.00 <sup>1)</sup>	2.85 <sup>1)</sup>	4.10	5.35	2.75	- 3.90	1.95 <sup>3)</sup>	2.75 <sup>3)</sup>	3.90	5.05
		5	4.40	- 4.90	2.00 <sup>1)</sup>	2.85 <sup>1)</sup>	4.05	5.30	3.50	- 4.90	1.90 <sup>3)</sup>	2.75 <sup>3)</sup>	3.85	5.00
		6	5.25	- 5.55	2.00 <sup>1)</sup>	2.80 <sup>1)</sup>	4.00	5.25	4.25	- 5.90	1.90 <sup>3)</sup>	1.90 <sup>3)</sup>	3.75	4.85
		7	-	-	-	-	-	-	4.95	- 6.90	1.60 <sup>3)</sup>	1.55 <sup>3)</sup>	3.70	4.80
		8	-	-	-	-	-	-	5.60	- 7.70	1.40 <sup>3)</sup>	1.35 <sup>3)</sup>	3.65	4.75

1) Two trolleys on each end of crane

2) Double trolley unit

3) Quadruple trolley on each end of crane

Load capacity: 630 kg, hoist weight: 75 kg, max. lifting speed: 15 m/min

	Profile	I <sub>HT</sub>	Single-girder crane						Double-girder crane						
			I <sub>Kr</sub>		I <sub>w</sub>				I <sub>Kr</sub>		I <sub>w</sub>				
			Min.	Max.	AL12	AL16	AL18	AL22	Min.	Max.	AL12	AL16	AL18	AL22	
Crane girder section, crane girder length	AL18	1	-	-	-	-	-	-	-	-	-	-	-	-	-
		2	1.75	- 1.90	1.85 <sup>1)</sup>	2.00 <sup>1)</sup>	3.70	4.85	1.50	- 1.90	1.35 <sup>3)</sup>	1.30 <sup>3)</sup>	3.65	4.75	
		3	2.70	- 2.90	1.85 <sup>1)</sup>	1.75 <sup>1)</sup>	3.70	4.85	1.95	- 2.90	1.20 <sup>3)</sup>	1.20 <sup>3)</sup>	3.60	4.70	
		4	3.65	- 3.80	1.65 <sup>1)</sup>	1.60 <sup>1)</sup>	3.70	4.80	2.85	- 3.90	1.10 <sup>3)</sup>	1.10 <sup>3)</sup>	3.55	4.65	
		5	-	-	-	-	-	-	3.70	- 4.90	1.05 <sup>3)</sup>	1.05 <sup>3)</sup>	3.55	4.60	
		6	-	-	-	-	-	-	4.50	- 5.30	0.95 <sup>3)</sup>	0.95 <sup>3)</sup>	3.50	4.50	
		7	-	-	-	-	-	-	5.25	- 5.30	0.90 <sup>3)</sup>	0.90 <sup>3)</sup>	3.45	4.45	
		8	-	-	-	-	-	-	-	-	-	-	-	-	
	AL22	1	-	-	-	-	-	-	-	-	-	-	-	-	
		2	1.75	- 1.90	1.85 <sup>1)</sup>	1.90 <sup>1)</sup>	3.70	4.85	1.50	- 1.90	1.30 <sup>3)</sup>	1.25 <sup>3)</sup>	3.65	4.70	
		3	2.70	- 2.90	1.80 <sup>1)</sup>	1.65 <sup>1)</sup>	3.70	4.85	1.95	- 2.90	1.15 <sup>3)</sup>	1.15 <sup>3)</sup>	3.60	4.65	
		4	3.60	- 3.90	1.60 <sup>1)</sup>	1.50 <sup>1)</sup>	3.65	4.80	2.80	- 3.90	1.05 <sup>3)</sup>	1.05 <sup>3)</sup>	3.55	4.60	
		5	4.50	- 4.90	1.40 <sup>1)</sup>	1.35 <sup>1)</sup>	3.65	4.75	3.60	- 4.90	1.00 <sup>3)</sup>	1.00 <sup>3)</sup>	3.50	4.55	
		6	-	-	-	-	-	-	4.40	- 5.90	0.90 <sup>3)</sup>	0.90 <sup>3)</sup>	3.45	4.45	
		7	-	-	-	-	-	-	5.15	- 6.90	0.85 <sup>3)</sup>	0.85 <sup>3)</sup>	3.40	4.40	
		8	-	-	-	-	-	-	5.85	- 6.90	0.85 <sup>3)</sup>	0.85 <sup>3)</sup>	3.35	4.35	

- 1) Two trolleys on each end of crane
- 2) Double trolley unit
- 3) Quadruple trolley on each end of crane

**Load capacity: 800 kg, hoist weight: 75 kg, max. lifting speed: 15 m/min**

	Profile	I <sub>HT</sub>	Single-girder crane						Double-girder crane					
			I <sub>Kr</sub>		I <sub>w</sub>				I <sub>Kr</sub>		I <sub>w</sub>			
			Min.	Max.	AL12	AL16	AL18	AL22	Min.	Max.	AL12	AL16	AL18	AL22
Crane girder section, crane girder length	AL18	1	-	-	-	-	-	-	-	-	-	-	-	
		2	1.50	- 1.90 <sup>2)</sup>	-	-	3.35 <sup>1)</sup>	4.40 <sup>1)</sup>	1.50	- 1.90	0.80 <sup>3)</sup>	0.80 <sup>3)</sup>	3.35	4.30
		3	2.50	- 2.90 <sup>2)</sup>	-	-	3.35 <sup>1)</sup>	4.35 <sup>1)</sup>	2.00	- 2.90	0.75 <sup>3)</sup>	0.75 <sup>3)</sup>	3.30	4.25
		4	-	-	-	-	-	-	2.90	- 3.90	0.75 <sup>3)</sup>	0.75 <sup>3)</sup>	3.25	4.25
		5	-	-	-	-	-	-	3.75	- 4.80	0.75 <sup>3)</sup>	0.75 <sup>3)</sup>	3.25	4.20
		6	-	-	-	-	-	-	4.60	- 4.80	0.70 <sup>3)</sup>	0.70 <sup>3)</sup>	3.20	4.15
		7	-	-	-	-	-	-	-	-	-	-	-	-
		8	-	-	-	-	-	-	-	-	-	-	-	-
	AL22	1	-	-	-	-	-	-	-	-	-	-	-	
		2	1.50	- 1.90 <sup>2)</sup>	-	-	3.35 <sup>1)</sup>	4.35 <sup>1)</sup>	1.50	- 1.90	0.80 <sup>3)</sup>	0.80 <sup>3)</sup>	3.30	4.30
		3	2.45	- 2.90 <sup>2)</sup>	-	-	3.35 <sup>1)</sup>	4.35 <sup>1)</sup>	1.95	- 2.90	0.75 <sup>3)</sup>	0.75 <sup>3)</sup>	3.30	4.25
		4	3.40	- 3.90 <sup>2)</sup>	-	-	3.30 <sup>1)</sup>	4.30 <sup>1)</sup>	2.85	- 3.90	0.75 <sup>3)</sup>	0.75 <sup>3)</sup>	3.25	4.20
		5	4.30	- 4.45 <sup>2)</sup>	-	-	3.30 <sup>1)</sup>	4.30 <sup>1)</sup>	3.70	- 4.90	0.70 <sup>3)</sup>	0.70 <sup>3)</sup>	3.20	4.15
		6	-	-	-	-	-	-	4.50	- 5.90	0.70 <sup>3)</sup>	0.70 <sup>3)</sup>	3.15	4.10
		7	-	-	-	-	-	-	5.30	- 6.25	0.70 <sup>3)</sup>	0.70 <sup>3)</sup>	3.15	4.05
		8	-	-	-	-	-	-	6.05	- 6.25	0.65 <sup>3)</sup>	0.65 <sup>3)</sup>	3.10	4.00

- 1) Two trolleys on each end of crane
- 2) Double trolley unit
- 3) Quadruple trolley on each end of crane

**Load capacity: 1000 kg, hoist weight: 85 kg, max. lifting speed: 15 m/min**

	Profile	I <sub>HT</sub>	Single-girder crane						Double-girder crane					
			I <sub>Kr</sub>		I <sub>w</sub>				I <sub>Kr</sub>		I <sub>w</sub>			
			Min.	Max.	AL12	AL16	AL18	AL22	Min.	Max.	AL12	AL16	AL18	AL22
Crane girder section, crane girder length	AL18	1	-	-	-	-	-	-	-	-	-	-	-	
		2	1.55	- 1.90 <sup>2)</sup>	-	-	3.00 <sup>1)</sup>	3.95 <sup>1)</sup>	1.50	- 1.90	-	-	3.00	3.90
		3	2.50	- 2.90 <sup>2)</sup>	-	-	3.00 <sup>1)</sup>	3.90 <sup>1)</sup>	2.00	- 2.90	-	-	3.00	3.85
		4	-	-	-	-	-	-	2.95	- 3.90	-	-	2.95	3.85
		5	-	-	-	-	-	-	3.80	- 4.30	-	-	2.95	3.80
		6	-	-	-	-	-	-	-	-	-	-	-	-
	AL22	1	-	-	-	-	-	-	-	-	-	-	-	
		2	1.50	- 1.90 <sup>2)</sup>	-	-	3.00 <sup>1)</sup>	3.95 <sup>1)</sup>	1.50	- 1.90	-	-	3.00	3.85
		3	2.50	- 2.90 <sup>2)</sup>	-	-	3.00 <sup>1)</sup>	3.90 <sup>1)</sup>	2.00	- 2.90	-	-	3.00	3.85
		4	3.45	- 3.90 <sup>2)</sup>	-	-	3.00 <sup>1)</sup>	3.90 <sup>1)</sup>	2.90	- 3.90	-	-	2.95	3.80
		5	-	-	-	-	-	-	3.75	- 4.90	-	-	2.95	3.80
		6	-	-	-	-	-	-	4.60	- 5.60	-	-	2.90	3.75
		7	-	-	-	-	-	-	5.45	- 5.60	-	-	2.90	3.70
		8	-	-	-	-	-	-	-	-	-	-	-	-

- 1) Two trolleys on each end of crane
- 2) Double trolley unit

**Load capacity: 1250 kg, hoist weight: 115 kg, max. lifting speed: 10 m/min**

	Profile	I <sub>HT</sub>	Double-girder crane					
			I <sub>Kr</sub>		I <sub>w</sub>			
			Min.	Max.	AL12	AL16	AL18	AL22
Crane girder section, crane girder length	AL18	1	-	-	-	-	-	-
		2	1.50	1.90	-	-	1.30	3.50
		3	2.05	2.90	-	-	1.25	3.50
		4	2.95	3.85	-	-	1.15	3.45
		5	-	-	-	-	-	-
		6	-	-	-	-	-	-
	AL22	1	-	-	-	-	-	-
		2	1.50	1.90	-	-	1.30	3.50
		3	2.00	2.90	-	-	1.20	3.50
		4	2.95	3.90	-	-	1.15	3.45
		5	3.85	4.90	-	-	1.05	3.45
		6	4.70	5.00	-	-	1.00	3.40
		7	-	-	-	-	-	-
		8	-	-	-	-	-	-

**Load capacity: 1600 kg, hoist weight: 115 kg, max. lifting speed: 10 m/min**

	Profile	I <sub>HT</sub>	Double-girder crane					
			I <sub>Kr</sub>		I <sub>w</sub>			
			Min.	Max.	AL12	AL16	AL18	AL22
Crane girder section, crane girder length	AL18	1	-	-	-	-	-	-
		2	1.50	1.90	-	-	0.75 <sup>1)</sup>	1.25 <sup>1)</sup>
		3	2.05	2.90	-	-	0.75 <sup>1)</sup>	1.20 <sup>1)</sup>
		4	3.00	3.50	-	-	0.60 <sup>1)</sup>	1.15 <sup>1)</sup>
		5	-	-	-	-	-	-
		6	-	-	-	-	-	-
	AL22	1	-	-	-	-	-	-
		2	1.50	1.90	-	-	0.75 <sup>1)</sup>	1.25 <sup>1)</sup>
		3	2.05	2.90	-	-	0.75 <sup>1)</sup>	1.20 <sup>1)</sup>
		4	2.95	3.90	-	-	0.70 <sup>1)</sup>	1.15 <sup>1)</sup>
		5	3.90	4.50	-	-	0.70 <sup>1)</sup>	0.55 <sup>1)</sup>
		6	-	-	-	-	-	-

<sup>1)</sup> Quadruple trolley on each end of crane

Load capacity: 2000 kg, hoist weight: 115 kg, max. lifting speed: 5 m/min

	Profile	I <sub>HT</sub>	Double-girder crane					
			I <sub>Kr</sub>		I <sub>w</sub>			
			Min.	Max.	AL12	AL16	AL18	AL22
Crane girder section, crane girder length	AL18	1	-	-	-	-	-	-
		2	1.50	- 1.90	-	-	0.60 <sup>1)</sup>	0.75 <sup>1)</sup>
		3	2.05	- 2.90	-	-	0.60 <sup>1)</sup>	0.75 <sup>1)</sup>
		4	3.00	- 3.15	-	-	0.55 <sup>1)</sup>	0.75 <sup>1)</sup>
	AL22	1	-	-	-	-	-	-
		2	1.50	- 1.90	-	-	0.60 <sup>1)</sup>	0.75 <sup>1)</sup>
		3	2.05	- 2.90	-	-	0.60 <sup>1)</sup>	0.75 <sup>1)</sup>
		4	3.00	- 3.90	-	-	0.55 <sup>1)</sup>	0.70 <sup>1)</sup>
		5	3.90	- 4.10	-	-	0.55 <sup>1)</sup>	0.70 <sup>1)</sup>
		6	-	-	-	-	-	-

<sup>1)</sup> Quadruple trolley on each end of crane

### 4.12 Structural dimensions for cranes

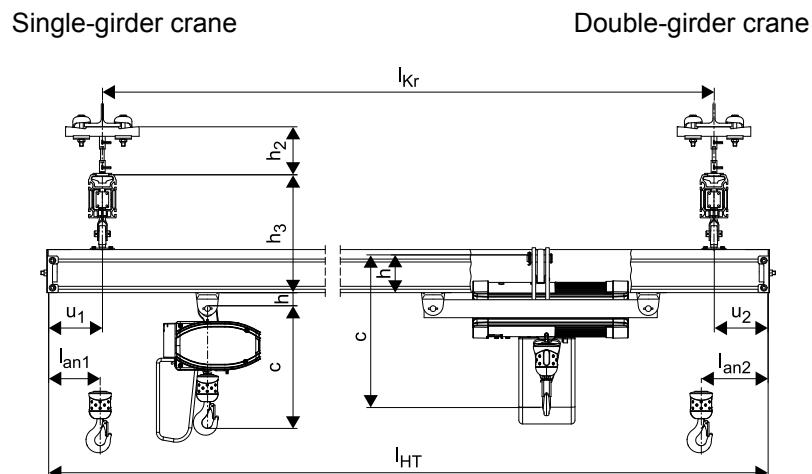

The lifting height achieved by using a double-girder crane is higher than that of single-girder cranes, as the hoist is positioned between the two crane girders.

#### Dimension h<sub>2</sub>

Dimension h <sub>2</sub> [mm] (I-beam bottom edge to track girder top edge)				
	Short suspension with spring clip	Length of suspension rod for spring clip		
		80	100	300
AL12/AL16	75	135	-	355
AL18/AL22	115	-	195	395

For I<sub>w</sub>, I<sub>Kr</sub>, I<sub>HT</sub> see diagram ([Profile load capacities according to the diagram \(page 17\)](#)) and selection tables ([Specifying single and double-girder cranes according to selection tables \(page 25\)](#))

u, st, I<sub>an</sub> according to specification and individual dimensions of components.



**Dimension h<sub>3</sub>**

Dimension h <sub>3</sub> [mm] (track girder top edge to crane girder bottom edge)														
Cranes														
AL crane runway		AL12			AL16			AL18				AL22		
AL crane girder		AL12	AL16	AL18	AL12	AL16	AL18	AL12	AL16	AL18	AL22	AL16	AL18	AL22
Track trolley	Single	330	370	390	370	410	430	390	430	450	490	470	490	530
	Double	340	380	400	380	420	440	405	445	465	505	485	505	545

Rigid crane end carriages: + 15

**Dimension h**

Dimension h [mm] (bottom edge of rail to top edge of pin)						
Cranes						
AL profile section		AL12	AL16	AL18	AL22	AL22 > 1.2 t
Cross-travel unit	Single	37		35		-
	Double	47		50		-
	Crab frame	-105		-150		-196

**Dimension c = hoist headroom dimension**

## 5 CRANE RUNWAY AND CRANE GIRDER BASIC COMPONENTS

### 5.1 Crane and track elements

#### 5.1.1 Straight section (item 1)

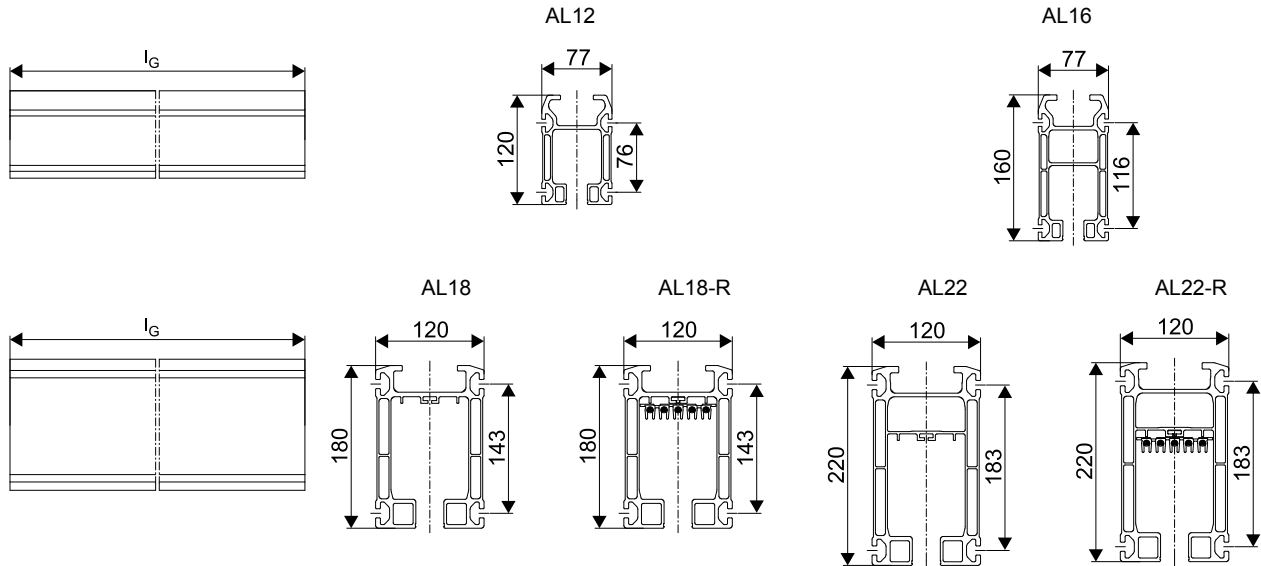

Item	Designation	Length $l_G$		AL12	AL16	AL18	AL18-R	AL22	AL22-R
1	Straight section	1000 mm	Weight [kg]	5.45	7.02	10.30	11.50	11.97	13.17
			Part no.	855 301 44	855 401 44	855 501 44	855 801 44	855 601 44	855 901 44
		2000 mm	Weight [kg]	10.90	14.04	20.60	23.00	23.94	26.34
			Part no.	855 302 44	855 402 44	855 502 44	855 802 44	855 602 44	855 902 44
		3000 mm	Weight [kg]	16.35	21.06	30.90	34.50	35.91	40.51
			Part no.	855 303 44	855 403 44	855 503 44	855 803 44	855 603 44	855 903 44
		4000 mm	Weight [kg]	21.80	28.08	41.20	46.00	47.88	52.68
			Part no.	855 304 44	855 404 44	855 504 44	855 804 44	855 604 44	855 904 44
		5000 mm	Weight [kg]	27.25	35.10	51.50	57.50	59.85	65.85
			Part no.	855 305 44	855 405 44	855 505 44	855 805 44	855 605 44	855 905 44
		6000 mm	Weight [kg]	32.70	42.12	61.80	69.00	71.82	79.02
			Part no.	855 306 44	855 406 44	855 506 44	855 806 44	855 606 44	855 906 44
		7000 mm	Weight [kg]	38.15	49.14	72.10	80.50	83.79	92.19
			Part no.	855 307 44	855 407 44	855 507 44	855 807 44	855 607 44	855 907 44
		8000 mm	Weight [kg]	43.60	56.16	82.40	92.00	95.76	105.36
			Part no.	855 308 44	855 408 44	855 508 44	855 808 44	855 608 44	855 908 44

### Integrated conductor line

AL18-R and AL22-R straight track sections are fitted with five internal conductor rails (10 mm<sup>2</sup> cross-section, up to 60 A, 500 V) which are enclosed over their entire length. If no control functions or zero have to be transmitted, only 4 conductors are connected.

AL straight sections without protective earth conductor on application.

#### Type of enclosure:

IP 23 to DIN 40050.

#### Designation of conductor rails:

1-3 = L1- L3

4 = control conductor

PE

Special lengths can be supplied ex works

(Minimum length: AL12/AL16 = 170 mm, AL18/AL22 = 220 mm).

**Finish:** anodized

### Suspension of straight sections

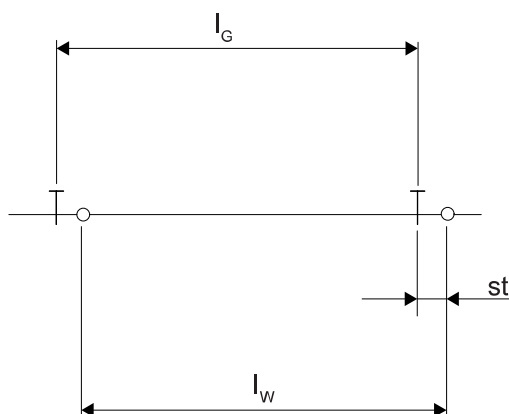

See sections [Reading off from the diagram \(page 19\)](#) to [System dimensions and system limits \(page 21\)](#) for distance between suspensions  $l_w$  and distance of joint from suspension fitting  $st$ .

### 5.1.2 Aligning device

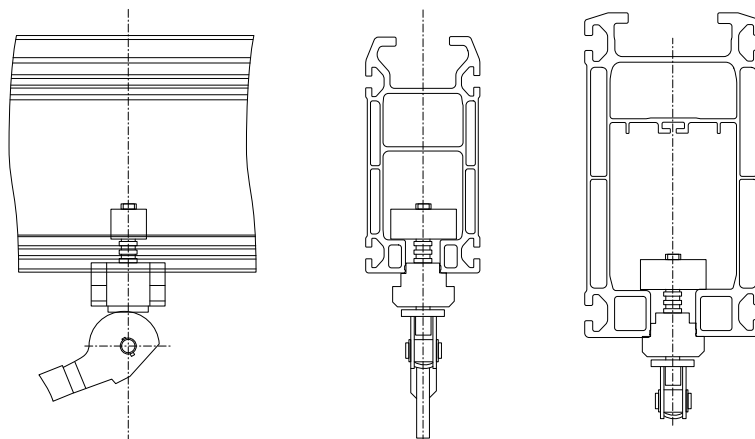

Item	Designation		AL12/AL16, AL18/AL22
180	Aligning device	Weight [kg]	0.33
		Part no.	855 190 44

This device simplifies alignment of the profile sections with each other when tracks are joined together.

### 5.2 Joint bolt set (item 2) and conductor joint set (item 3)

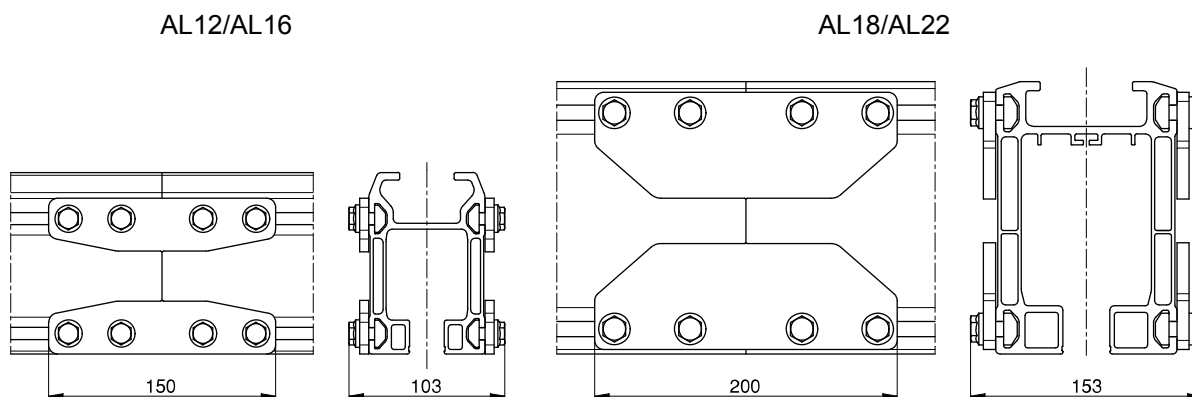

Item	Designation		AL12	AL16	AL18	AL18-R	AL22	AL22-R
2	Joint bolt set	Weight [kg]	1.35	1.35	4.09	4.09	4.09	4.09
		Part no.	855 423 44	855 423 44	855 623 44	855 623 44	855 623 44	855 623 44
3	Conductor joint set	Weight [kg]	-	-	-	0.07	-	0.07
		Part no.				873 649 44		873 649 44

The joint bolt set consists of patterned link plates that are bolted to the side and located by the slots.

For AL-R sections, a conductor joint set is required in addition to the bolted connection at each track joint. The set consists of five conductor rail connectors which are pressure-fitted to establish electric contact, and one plastic connector ensuring the mechanical connection of the conductor rail system.

The connection is a positive and friction connection.

**Finish:** galvanized

### 5.3 Internal buffer stop (item 6)

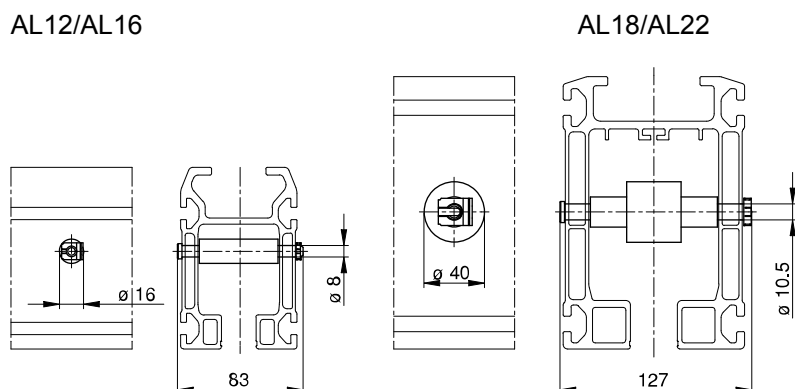

Item	Designation		AL12/AL16	AL18/AL22
6	Internal buffer stop	Weight [kg]	0.04	0.25
		Part no.	855 420 44	855 620 44

An internal buffer stop is fitted as protection for accumulated cable sliders (item 85) and cable trolleys (item 86) and to limit crane or hoist trolley travel.

**Finish:** Vulkollan/galvanized

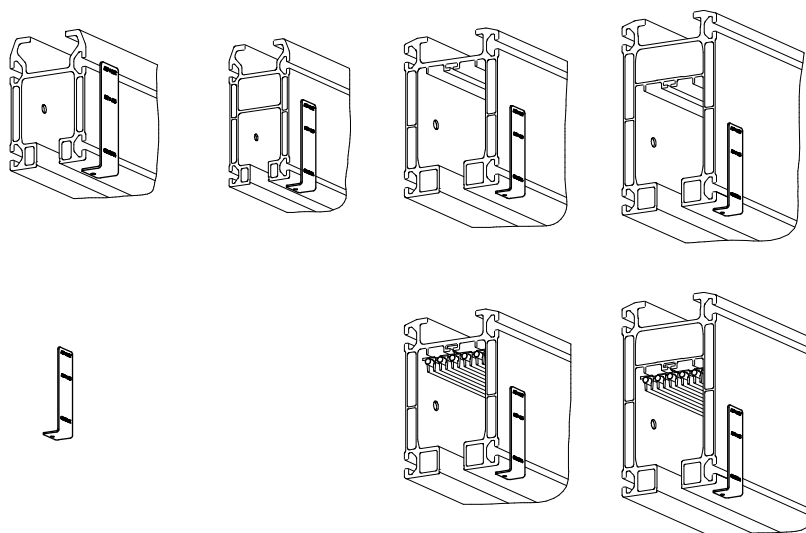

Item	Designation		AL12/AL16	AL18/AL22
175	Drilling template	Weight [kg]	0.04	
		Part no.	855 691 44	

The bore hole template can be used to simply mark the bore hole position for an internal buffer stop.

### 5.4 End cap with buffer (item 7) (item 7e)

AL12/AL16

End cap with buffer

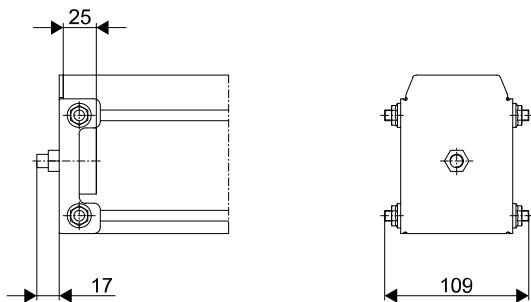

AL18/AL22

End cap with buffer

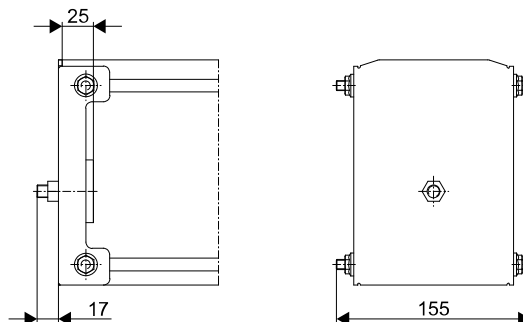

End cap with cellular plastic buffer

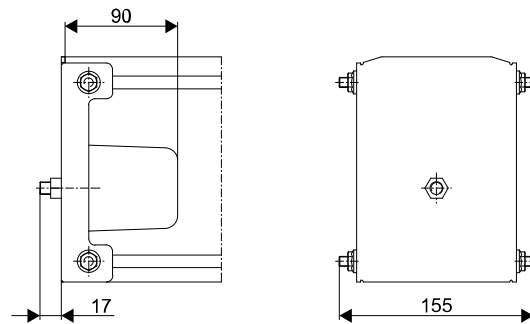

Item	Designation		AL12	AL16	AL18	AL18-R	AL22	AL22-R
7	End cap with buffer	Weight [kg]	0.38	0.45	0.71	0.93	0.81	1.04
		Part no.	855 326 44	855 426 44	855 526 44	855 826 44	855 626 44	855 926 44
7e	End cap with cellular plastic buffer <sup>1)</sup>	Weight [kg]	-	-	0.85	-	0.95	-
		Part no.	-	-	855 530 44	-	855 630 44	-

<sup>1)</sup> Use trolley buffer plate, see [Buffer on AL18/AL22 single trolley inside the profile section \(page 83\)](#)

An end cap is fitted as a termination for tracks and crane girders.

End caps with rubber buffers are used for lighter loads.

End caps with cellular plastic buffers can be used on AL18/AL22 for heavy loads, electric and pneumatic drives and for crane runways.

**All installations must be dimensioned in such a way that the end caps and internal buffer stops are not approached during normal operation.**

**Finish:** black (RAL 9005), steel

## 5.5 AL-R components

The following components can be used in installations that have internal conductor lines (AL-R profile sections, see [Crane and track elements \(page 38\)](#)).

### 5.5.1 Powerfeed end cap (item 8)

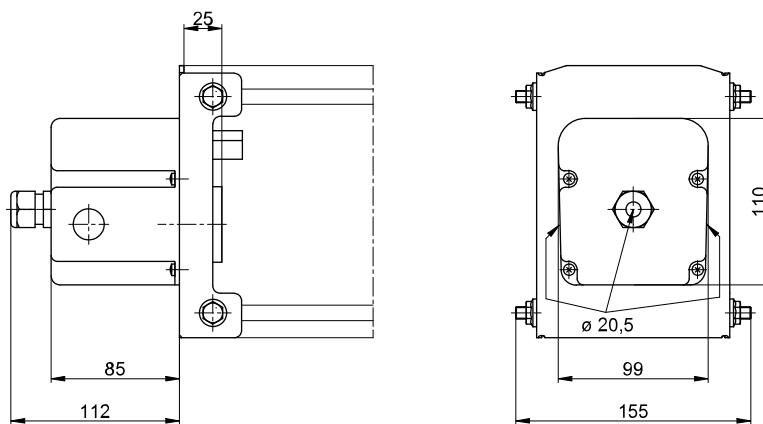

Item	Designation		AL18-R	AL22-R
8	Powerfeed end cap	Weight [kg]	1.08	1.19
		Part no.	855 820 44	855 920 44

The powerfeed end cap is used to supply power to the end of a AL rail. It consists of an end cap with buffer and a terminal box.

The terminal box includes an M20 union on its end face. Prepared openings of 20.5 mm and 25.5 mm in diameter are provided on the side (max. connection cross-section 10 mm<sup>2</sup>).

The powerfeed end cap is supplied pre-assembled with attached plug connectors and connecting cables. Powerfeed end caps without protective earth conductor available on application.

**Finish:** black

### 5.5.2 DFL fixed points (item 210)

Item	Designation		AL18/AL22
200	Fixed points (40 off)	Weight [kg]	0.04
		Part no.	855 912 44

A DFL internal conductor line can be added to AL18 and AL22 sections. In addition to the conductor line, 4 fixed points are required for each straight section.

The DFL conductor line must be ordered separately.

See operating instructions for assembly.

### 5.5.3 Current collector trolley (item 12)

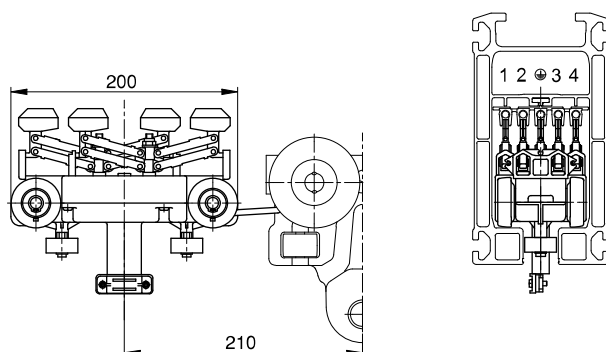

Designation of the sliding contacts:

1 = L1

2 = L2

 = PE

3 = L3

4 = Control conductor

Item	Designation		AL18-R/AL22-R 5-pole
12	Current collector trolley (5-pole)	Weight [kg]	1.50
		Part no.	855 985 44

For reliable current collection, the 5-pole AL-R current collector is fitted with two sliding contacts mounted on individually spring-loaded double pantographs for each conductor rail. The connecting cable is 2 m long.

Maximum load: 15 A at 100% cyclic duty factor.

The current collector trolley is guided by two support rollers in the track section and runs on four plastic wheels mounted on anti-friction bearings which are lubricated for life. The traction resistance is approx. 2 kg. A coupling is used for connection to a AL load trolley.

**Current collector trolleys must always be arranged to run between two trolleys. These are used to protect against collisions.**

Current collector trolleys without protective earth conductor available on application.

## 5.6 Information plates

Capacity plate (item 15)

Name plate (item 16)

# 250 KG

**SWF** ProfileMaster PLUS AL  
KRANTECHNIK

Item	Designation	Load capacity	AL12/AL16	AL18/AL22
		[kg]	h = 40 mm Part no.	h = 60 mm Part no.
15	Capacity plate	63	854 031 44	-
		125	854 032 44	854 041 44
		160	854 033 44	-
		250	854 034 44	854 042 44
		320	854 035 44	-
		500	854 036 44	854 043 44
		630	-	854 044 44
		800	-	854 045 44
		1000	-	854 046 44
		1250	-	854 047 44
		1600	-	854 048 44
		2000	-	854 049 44
16	Name plate	-	854 091 44	854 092 44

Capacity plates must be fitted to both sides of all crane bridges. The load capacity stated on the hoist and on the crane must be identical.

Capacity plates measuring 60 mm in height should be used for AL16 section sizes and larger.

**Type:**

Self-adhesive foil



## 6 TRACK SUSPENSION

### 6.1 Notes and overview

The examples of track suspensions shown on the following page are only some of the many combinations possible by using standard series-manufactured track suspension components.

#### Supporting structure

The owner is responsible for verification of superstructure/support structure.

#### Short suspension fitting

Particularly low suspension heights can be achieved by using short suspension arrangements.

#### Sloping superstructure

Suspension from sloping superstructures is also possible.

#### Stiffeners

On long suspension arrangements, with suspension rod lengths from approx. 600 mm upwards, undesirable pendulation of the track may occur. (This can already occur in small installations and when electric drives are used with short suspensions). This can be limited by fitting longitudinal and lateral stiffeners.

Transverse stiffeners should be fitted approx. every 15 m for AL12/AL16 and approx. every 20 m for AL18/AL22 for crane runway tracks. One stiffener is usually sufficient in the longitudinal direction. All crane runways must be provided with stiffeners.

Transverse and longitudinal stiffeners are of V-type stiffener design.

#### V-type suspension fittings

V-type suspension fittings may also replace missing suspension points in vertical suspension arrangements. Max. vertical dimension as for vertical suspension arrangements.

#### Load capacity, dimensions for suspension from I-beam superstructures, height compensation

	Thread	Load capacity <sup>1)</sup>	Suspension dimension h <sub>2</sub>		h <sub>1</sub>
			Adjustable short suspension [mm]	Suspension with suspension rod 80/100 mm	Max. suspension rod length [m]
AL12/AL16	M10	750	73 ± 4	134 ± 9	1
AL18	M16 x 1.5	1400	115 ± 7	195 ± 14	3
AL22	M16 x 1.5	1700	115 ± 7	195 ± 14	3

<sup>1)</sup> Static or alternating load

Examples

Short, adjustable

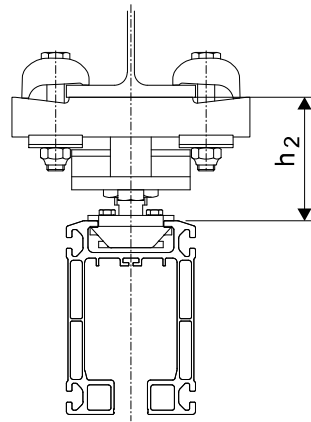

With suspension rod

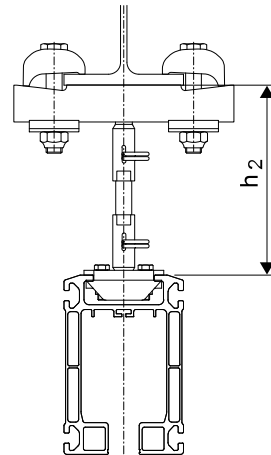

On anchor bolts <sup>1)</sup>

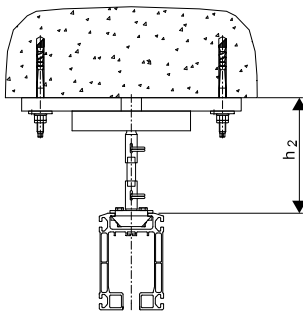

From U-bolt

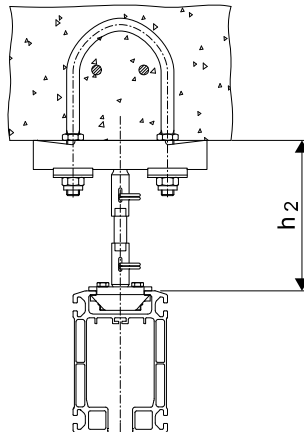

From brackets

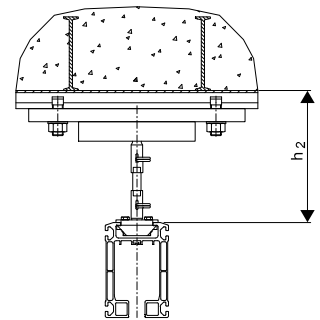

With floor plate

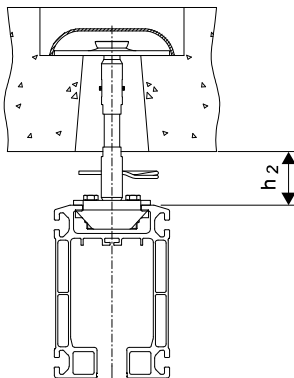

Drilled

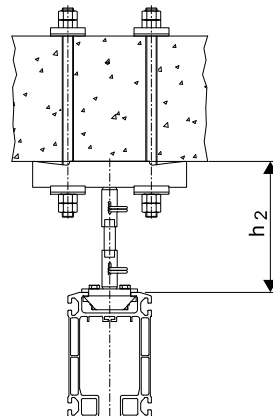

On wooden beam

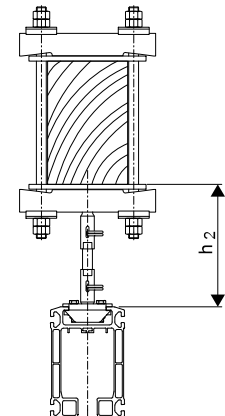

V-type suspension fitting

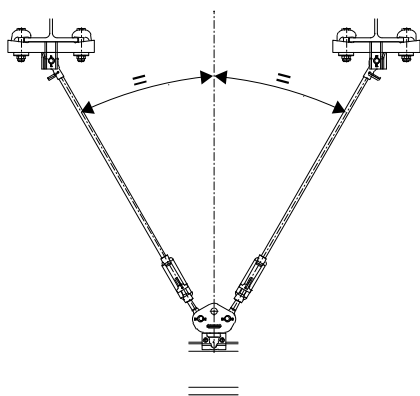

Sloping V-type suspension

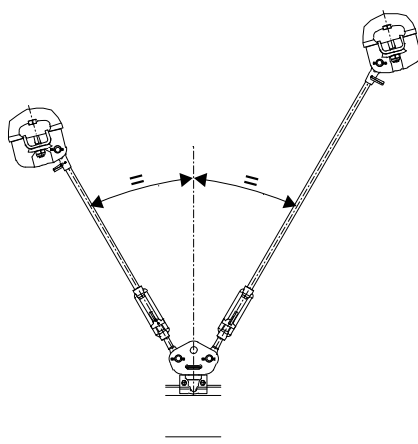

Sloping suspension

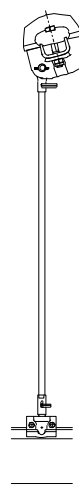

Lateral stiffener

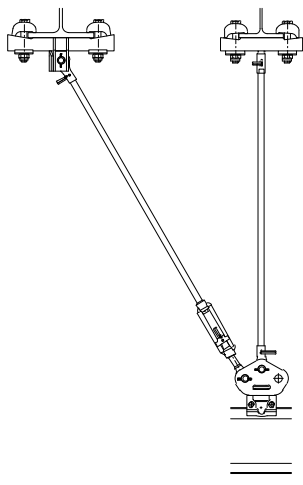

Lateral stiffener

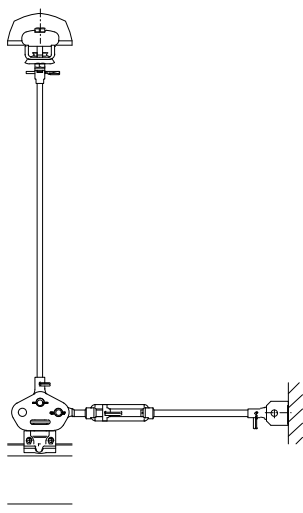

V-type stiffener

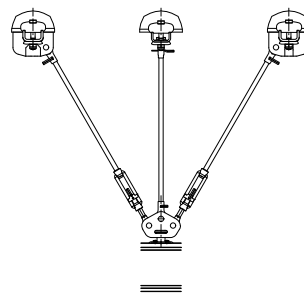

Sloping stiffener

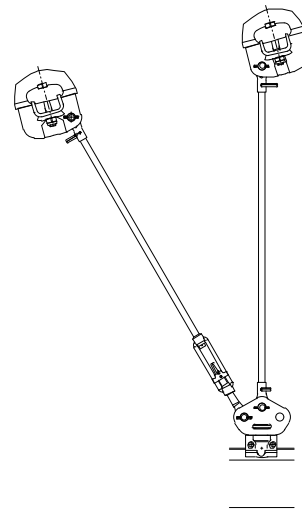

1) See technical guide 231 014 44 for description.

## 6.2 Vertical suspension on I-beams

Classic suspensions are flexible, ball-and-socket universal joint suspension arrangements featuring minimum torque transmission to roof and ceiling superstructures and minimum lateral forces transmitted to the track system

### 6.2.1 I-beam assignment

Profile		Suitable for profile sections		
		I	IPE	HE-B (IPB)
AL12/AL16	Upper suspension bracket A	140 - 260	120 - 270	100 - 140
	Upper suspension bracket B	-	220 - 450	120 - 200
AL18/AL22	Upper suspension bracket A	140 - 320	140 - 270	100 - 120
	Upper suspension bracket B	220 - 450	180 - 500	100 - 200

Upper suspension bracket A can be used on roof structures and steel profile sections; upper suspension bracket B (ends project beyond bearing surface) is only suitable for steel profile sections.

The special clamp design ensures that the bolt of the clamp is always vertical regardless of the beam flange thickness.

Higher flange bending stresses can occur, for example, when used on HE-A beams.

### 6.2.2 Suspension with suspension rod

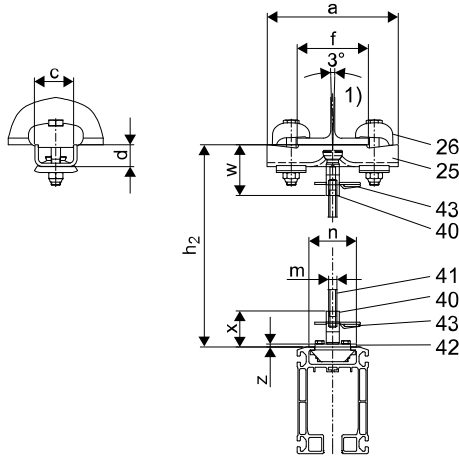

1) Max. girder gradient  $\pm 1.5^\circ$

Profile	$h_2$ [mm]	m [mm]	n [mm]	w [mm]	x [mm]	z [mm]
AL12/AL16	$54 + h_1 \pm 9$	M10	70	60	40	4
AL18/AL22	$95 + h_1 \pm 14$	M16x1.5	90	95	60	5

Profile		a [mm]	f [mm]	c [mm]	d [mm]
AL12/AL16	Upper suspension bracket A	205	66 - 142	70	27
	Upper suspension bracket B	270	110 - 210		23
AL18/AL22	Upper suspension bracket A	221	71 - 139	72	37
	Upper suspension bracket B	290	100 - 208	76	36

### Complete suspension fittings, pre-assembled (item 30)

Item	Designation	Suspension rod  h <sup>1</sup> = [mm]	Upper suspension bracket  Type	AL12/AL16 (750 kg)		AL18 (1400 kg) AL22 (1700 kg)	
				Weight [kg]	Part no.	Weight [kg]	Part no.
30	Complete suspension with suspension rod	80	A	2.10	855 169 44	-	-
			B	2.33	517 729 46	-	-
		100	A	-	-	4.18	855 175 44
			B	-	-	5.02	855 176 44
		300	A	2.23	517 730 46	4.50	517 740 46
			B	2.47	517 731 46	5.34	517 741 46
		600	A	2.42	517 732 46	4.97	517 742 46
			B	2.65	517 733 46	5.81	517 743 46
1000	A	2.66	517 734 46	5.60	517 744 46		
	B	2.90	517 735 46	6.44	517 745 46		

### Suspension fitting component parts

Item	Designation	h <sub>1</sub> [mm]	AL12/AL16 (750 kg)			AL18 (1400 kg) AL22 (1700 kg)		
			Weight [kg]	Part no.	[Qty/susp.]	Weight [kg]	Part no.	[Qty/susp.]
25	Upper suspension bracket A		0.65	980 302 44	1	1,20	982 302 44	1
	Upper suspension bracket B		0.85	980 304 44		2,40	982 304 44	
26	Upper suspension clamp		0.45	980 326 44	2	1,00	982 326 44	2
40	Ball-head suspension rod		0.08	980 333 44	2	0,15	982 333 44	2
41	Suspension rod	80	0.07	980 346 44	1			1
		100				0,22	982 446 44	
		300	0.18	980 347 44		0,53	982 447 44	
		600	0.33	980 348 44		1,01	982 448 44	
		1000	0.53	980 349 44		1,64	982 449 44	
		3000			-	4,80	982 445 44	
42	Track suspension clamp		0.30	855 020 44	1	0,80	855 025 44	1
43	Spring clip		0.01	342 200 99	2	0,02	342 201 99	2

The ball-head suspension rod (item 40) and suspension rod coupling (item 50) are provided with slotted holes. The threaded rod (item 41) has a cross-hole at both ends. If standard threaded suspension rods have to be shortened, a new transverse hole must be drilled at the end of the threaded rod.

**Finish:** galvanized

#### Wearing parts

Item	Designation		AL12/AL16	AL18/AL22
42d	Sliding shell for ball-head suspension rod/ball-head bolt (25 off)	Weight [kg]	0.02	0.05
		Part no.	980 815 44	851 394 44

### Drilling jig (item 38)

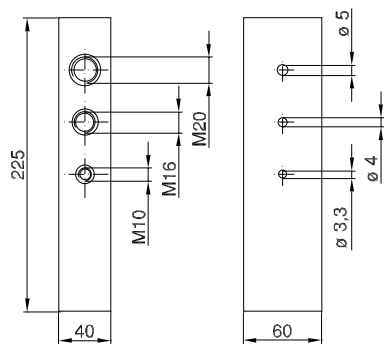

The drilling jig facilitates drilling transverse holes in suspension rods. This ensures that the distance to the end of the rod is reliably maintained.

Item	Designation		
38	Drilling jig for suspension rods	Weight [kg]	3.92
		Part no.	982 017 44

**Finish:** galvanized

### 6.2.3 Coupling for suspension rod (item 50)

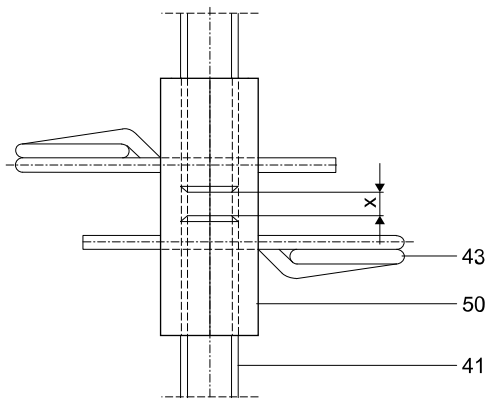

	x
AL12/AL16	0-3
AL18/AL22	0-4

Item	Designation		AL12/AL16	AL18/AL22
50	Coupling for suspension rod	Weight [kg]	0.10	0.17
		Part no.	980 277 44	982 277 44

Use couplings to connect several suspension rods.

**Finish:** galvanized

## 6.2.4 Short suspension arrangement with height adjustment

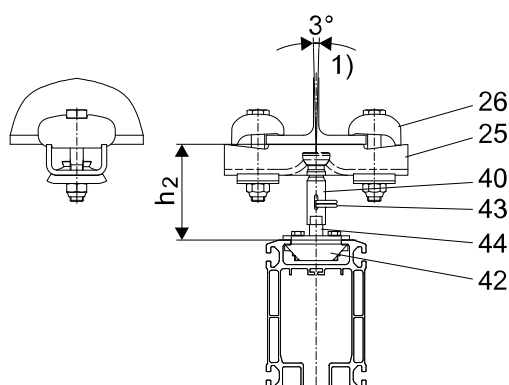

	<b>h<sub>2</sub></b> [mm]
AL12/AL16	73 ± 4
AL18/AL22	115 ± 7

### Complete suspension fittings, pre-assembled (item 31)

Item	Designation	Upper suspension bracket Type	AL12/AL16 (750 kg)		AL18 (1400 kg) AL22 (1700 kg)	
			Weight [kg]	Part no.	Weight [kg]	Part no.
31	Complete suspension, short, adjustable	A	2.02	855 167 44	3.98	855 173 44
		B	2.25	517 727 46	4.82	855 174 44

### Suspension fitting component parts

Item	Designation	AL12/AL16 (750 kg)			AL18 (1400 kg) AL22 (1700 kg)		
		Weight [kg]	Part no.	[Qty/susp.]	Weight [kg]	Part no.	[Qty/susp.]
25	Upper suspension bracket A	0.65	980 302 44	1	1.20	982 302 44	1
	Upper suspension bracket B	0.85	980 304 44		2.40	982 304 44	
26	Upper suspension clamp	0.45	980 326 44	2	1.00	982 326 44	2
40	Ball-head suspension rod	0.08	980 333 44	1	0.15	982 333 44	1
44	Ball-head bolt	0.06	980 283 44	1	0.14	982 283 44	1
42	Track suspension clamp	0.30	855 020 44	1	0.80	855 025 44	1
43	Spring clip	0.01	342 200 99	1	0.02	342 201 99	1

A particularly low suspension height can be achieved using the ball-head bolt/ball-head suspension rod connection arrangement with spring clip. Slotted holes facilitate height adjustment.

**Finish:** galvanized

Table 2. Wearing parts

Item	Designation		AL12/AL16	AL18/AL22
42d	Sliding shell for ball-head suspension rod/ball-head bolt (25 off)	Weight [kg]	0.02	0.05
		Part no.	980 815 44	851 394 44

### 6.3 Vertical suspension from U-sections

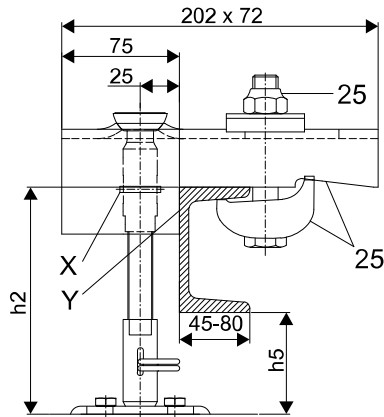

	$h_2$	$h_5$
AL12/AL16	$20 + h_1 \pm 9 > \text{track section height} + 40$	40
AL18/AL22	$50 + h_1 \pm 14 > \text{track section height} + 65$	65

Upper U-type suspension brackets can be used on U-shaped steel profile sections (DIN 1024).

The max. suspension load must be observed as specified in the table:

Item	Profile	Weight [kg]	Part no.	Max. load on suspension $G_{AB}$ [kg]	Steel girder section
25	AL12/AL16	2	980 377 44	750	U 80 - U 220
				750	U 80 - U 100
	AL18/AL22	2	984 377 44	1000	U 120 - U 140
				1250	U 160
				1400	U 180 - U 220

The free swing angle of the suspension fitting may be limited by the steel profile section. Use stiffeners, as required, to avoid any collision during operation.

Secure the connection between the ball-head suspension rod and the suspension rod with the enclosed spring pin (see "X").

Edge "Y" of the upper suspension bracket must be in close contact with the profile section.

The ball-head suspension rod, spring clip and suspension clamp must be ordered separately.

**Finish:** galvanized

The loads specified for individual profile sections must not be exceeded. The owner is responsible for verification of U-sections.



## 6.4 Ceiling attachment

### 6.4.1 Suspension with anchor bolt connection

Anchor bolt connection

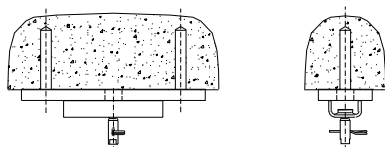

AL equipment can be attached to concrete superstructures by anchor bolts. Anchor bolts must be used that are approved for use with dynamic loads. They must be installed by trained personnel and an installation report must be compiled. Please also refer to data sheet 231 014 44.

### 6.4.2 U-bolt with upper suspension bracket A

U-bolt (item 27)

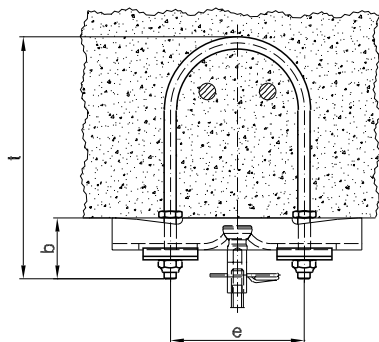

	b	e	t
AL12/AL16	50	110	200
AL18/AL22	70	120	225

Item	Designation	Qty/susp.	AL12/AL16		AL18/AL22	
			Weight [kg]	Part no.	Weight [kg]	Part no.
27	U-bolt (complete)	1	0.15	980 330 44	0.8	982 330 44

For new buildings, U-bolts can be cast in reinforced ceilings at the AL track suspension points while the building is still undergoing construction. This must be discussed with the structural engineer. U-bolts are used to secure upper suspension bracket A.

**Important:** To make it possible to align the track, the U-bolts should be cast in at right angles to the direction of the track.

**Finish:** galvanized

### 6.4.3 Suspension from ceiling section rails with upper suspension bracket A

packing plate (item 32),

lock nut (item 33),

packing plate for upper suspension bracket (item 51)

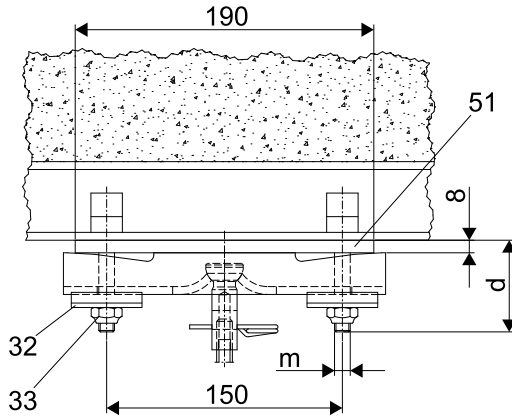

	d	m <sup>1)</sup>
AL12/AL16	70	M10
AL18/AL22	80	M16

1) or as indicated for cast-in section rail for upper suspension bracket H

See data referring to cast-in section rail for tightening torque M

Item	Designation	Qty/susp.	AL12/AL16		AL18/AL22	
			Weight [kg]	Part no.	Weight [kg]	Part no.
32	Packing plate	2	0.1	980 429 44	0.21	984 329 44
33	Locknut	2	-	334 610 44	-	334 614 44
51	Packing plate for upper suspension bracket	1	1.6	984 088 44	1.6	984 088 44

Suspension may only be from cast-in section rails that are approved for **dynamic loads**.

A-type upper suspension brackets are secured to section rails cast in concrete using a packing plate and two special bolts with nuts and tab washers. The M10 special bolts for AL12/AL16 and M16 for AL18/AL22 should be provided by the customer or can be supplied on application (specify section rail type).

**Ensure compliance with load-bearing capacity and correct length of special bolts.**

**Important:** This AL suspension fitting must be regarded as a concentrated load on the section rail (**low load-bearing capacity**).

**Finish:** galvanized

**Upper suspension brackets H** with bore hole spacing  $\geq 250$  mm count as dual load suspensions.

#### 6.4.4 Suspension with floor fixture plate and cover

- Floor fixture plate (item 35),
- cover for floor fixture plate (item 36),
- spring pin (item 37)

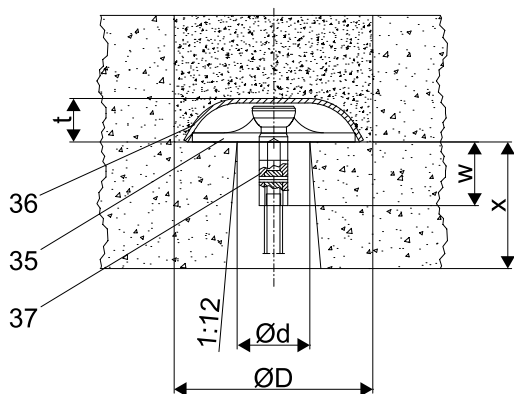

	d	D	t	w
AL12/AL16	40	110	25	35
AL18/AL22	60	150	28	60

Item	Designation	AL12/AL16		AL18/AL22	
		Weight [kg]	Part no.	Weight [kg]	Part no.
35	Floor slab	0.2	980 336 44	0.4	982 336 44
36	Cover	0.2	980 338 44	0.2	982 338 44
37	3 x 18 spring pin	-	345 095 99	-	-
	4 x 26 spring pin	-	-	-	345 008 99

In existing concrete buildings it is impossible to install a steel profile section without losing headroom. In such cases it is possible to make a hole in the ceiling at the suspension point and to use a floor fixture plate for the ball-head suspension rod with the cover for the floor fixture plate. The connection between the suspension rod and the ball-head suspension rod is often no longer accessible for maintenance and the two rods must be secured relative to each other by a spring pin instead of a spring clip. Arrangement of these suspension fittings, the loads to which they are subjected and dimension X should be agreed with the structural engineer or architect responsible.

Finish: galvanized

### 6.4.5 Suspension with upper suspension bracket A and suspension rods or positive anchors

Nut for suspension rod (item 39)

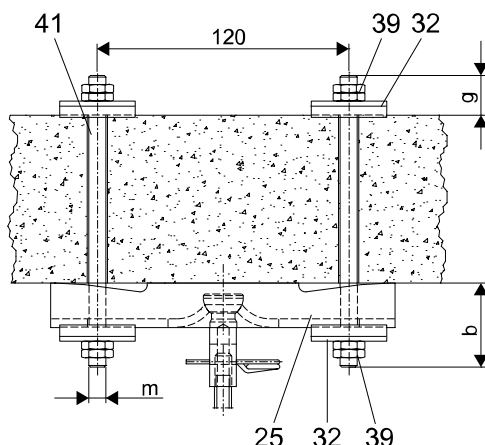

	b	g	m
AL12/AL16	60	35	M10
AL18/AL22	85	50	M16 x 1.5

Item	Designation	AL12/AL16 Part no.	AL18/AL22 Part no.
39	Nut for suspension rod	150 509 99	150 678 99

A-type upper suspension brackets can also be secured to solid ceilings by using two suspension rods with counter-plates. The transmission of forces to the concrete ceiling must be agreed with the structural engineer.

### 6.5 V-type suspension fitting

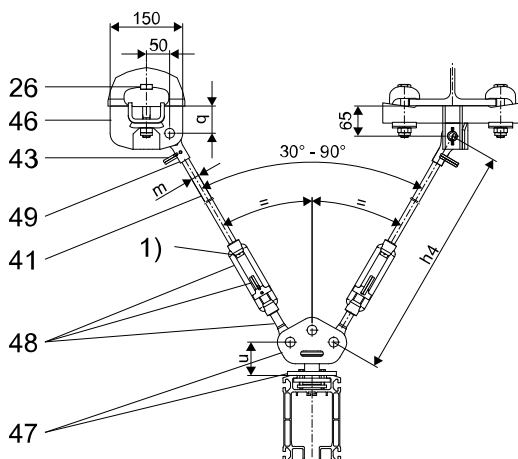

1) No spring clip fitted here

$h_1$  = suspension rod length

Profile	$h_4$ [mm]	m [mm]	q [mm]	u [mm]
AL12/AL16	$h_1 + 155 \pm 30$	M10	40	51
AL18/AL22	$h_1 + 220 \pm 40$	M16 x 1.5	55	69

Item	V-type suspension fitting, parallel or perpendicular	$h_1$ [mm]	AL12/AL16 (750 kg)			AL18 (1400 kg) AL22 (1700 kg)		
			Weight [kg/unit]	Part no.	[Qty/susp.]	Weight [kg/unit]	Part no.	[Qty/susp.]
26	Upper suspension clamp		0.45	980 326 44	4	1.00	982 326 44	4
40	Ball-head suspension rod		0.08	980 333 44		0.15	982 333 44	
41	Suspension rod	80	0.07	980 346 44	2			2
		100				0.22	982 446 44	
		300	0.18	980 347 44		0.53	982 447 44	
		600	0.33	980 348 44		1.01	982 448 44	
		1000	0.53	980 349 44		1.64	982 449 44	
		3000			-	4.80	982 445 44	
43	Spring clip		0.01	342 200 99	2	0.02	342 201 99	2
46	V-type upper suspension bracket B		1.39	980 360 44	2	3.20	984 075 44	2
47	V-type suspension clamp		1.24	855 160 44		2.56	855 166 44	1
54	Pin with BoClip for third hinged end piece		0.08	851 305 44		0.16	851 317 44	

Item	V-type suspension fitting, parallel or perpendicular	h <sub>1</sub> [mm]	AL12/AL16 (750 kg)			AL18 (1400 kg) AL22 (1700 kg)		
			Weight [kg/unit]	Part no. [Qty/susp.]	Weight [kg/unit]	Part no. [Qty/susp.]		
48	Suspension rod strainer		0.29	980 310 44 2	0.85	984 085 44 2		
49	Hinged end piece		0.10	980 315 44 2	0.30	984 083 44 2		

V-type suspensions are fitted as shown in the diagrams. V-type hinged suspension clamp (item 47) and V-type upper suspension bracket (item 46) are connected to each other by suspension rod strainer (item 48), suspension rod (item 41) and hinged end piece (item 49). Each bolted connection with a hinged end piece must be secured with a spring clip (item 43).

**The maximum permissible loads correspond to those for vertical suspension arrangements.**

**Finish:** galvanized

## 6.6 Stiffener

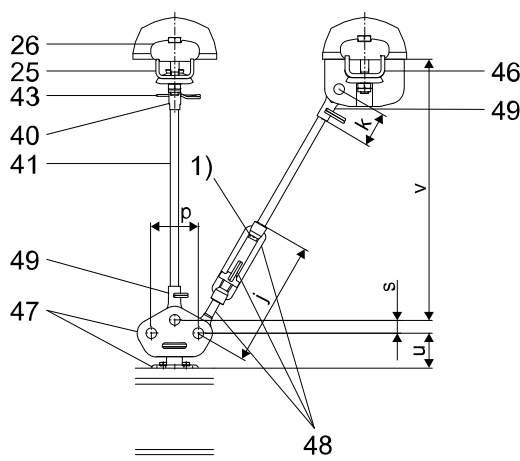

1) No spring clip fitted here

h<sub>1</sub> = suspension rod length

Profile	j [mm]	k [mm]	p [mm]	s [mm]	u [mm]	v [mm]
AL12/AL16	165 ± 15	50	60	20	51	h <sub>1</sub> + 65 ± 4
AL18/AL22	235 ± 20	65	90	25	69	h <sub>1</sub> + 100 ± 7

Item	Lateral stiffener, parallel or perpendicular	h <sub>1</sub> [mm]	AL12/AL16 (750 kg)			AL18 (1400 kg) AL22 (1700 kg)		
			Weight [kg/unit]	Part no. [Qty/susp.]	Weight [kg/unit]	Part no. [Qty/susp.]		
25	Upper suspension bracket A		0.65	980 302 44 1	1.20	982 302 44 1		
	Upper suspension bracket B		0.85	980 304 44 1	2.40	982 304 44 1		
26	Upper suspension clamp		0.45	980 326 44 4	1.00	982 326 44 4		
40	Ball-head suspension rod		0.08	980 333 44 1	0.15	982 333 44 1		

Item	Lateral stiffener, parallel or perpendicular	h <sub>1</sub> [mm]	AL12/AL16 (750 kg)			AL18 (1400 kg) AL22 (1700 kg)		
			Weight [kg/unit]	Part no.	[Qty/susp.]	Weight [kg/unit]	Part no.	[Qty/susp.]
41	Suspension rod	80	0.07	980 346 44	1+1			1+1
		100				0.22	982 446 44	
		300	0.18	980 347 44		0.53	982 447 44	
		600	0.33	980 348 44		1.01	982 448 44	
		1000	0.53	980 349 44		1.64	982 449 44	
		3000			-	4.80	982 445 44	
43	Spring clip		0.01	342 200 99	3	0.02	342 201 99	3
46	V-type upper suspension bracket B		1.39	980 360 44	1	3.20	984 075 44	1
47	V-type suspension clamp		1.24	855 160 44		2.56	855 166 44	1
54	Pin with BoClip for third hinged end piece		0.08	851 305 44		0.16	851 317 44	
47a	Filler plates for sloping surface				-			
48	Suspension rod strainer		0.29	980 310 44	1	0.85	984 085 44	1
49	Hinged end piece		0.10	980 315 44	2	0.30	984 083 44	2

Crane runway stiffener, perpendicular direction

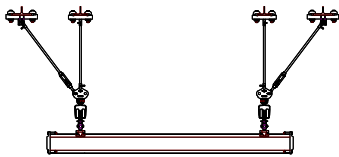

Track stiffener, longitudinal direction

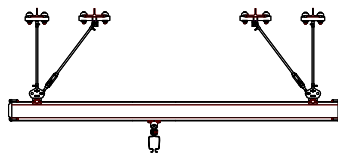

Not permitted for any profile sections

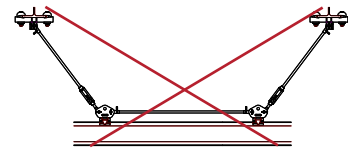

Stiffeners are fitted as shown in the diagrams. V-type hinged suspension clamp (item 47) and V-type upper suspension bracket (item 46) are connected to each other by suspension rod strainer (item 48), suspension rod (item 41) and hinged end piece (item 49). Each bolted connection with a hinged end piece must be secured with a spring clip (item 43).

Finish: galvanized

## 6.7 Component parts for V-type suspension/stiffener arrangement

### 6.7.1 V-type upper suspension bracket (item 46)

Pin axis parallel to V-type upper suspension bracket

1. May slope in this plane

2. Additional sloping plane is not possible

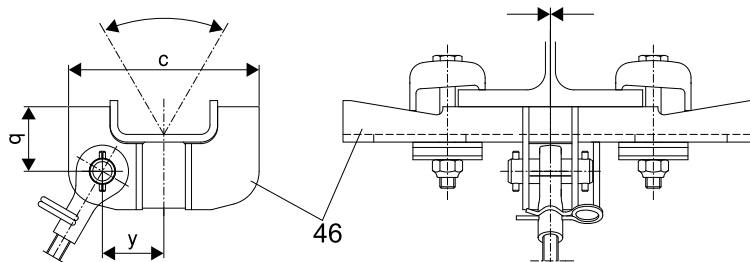

Pin axis perpendicular to V-type upper suspension bracket

1. May slope in this plane

2. Additional sloping plane is not possible

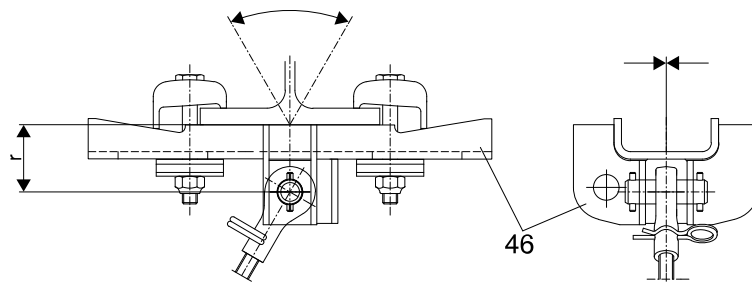

Profile	c [mm]	q [mm]	r [mm]	y [mm]
AL12/AL16	125	40	45	40
AL18/AL22	150	55	65	50

Item	Designation		AL12/AL16	AL18/AL22
46	V-type upper suspension bracket B	Weight [kg]	1.39	3.20
		Part no.	980 360 44	984 075 44

### Possible mounting configurations

V-type upper suspension brackets have a pin with spring pins (no hinged end piece).

Fit V-type upper suspension brackets to the superstructure in the same way as vertical suspension arrangements (e.g. with upper suspension clamps).

**V-type upper suspension brackets are the same size as upper suspension bracket B (the ends are higher).**

Upper suspension bracket A is not used for stiffeners/V-type suspensions because the girders which fit upper suspension bracket A do not always absorb the lateral and torsion forces. For smaller girders: adapters available on request.

The V-type upper suspension bracket is designed for connecting **one** suspension rod by means of a hinged end piece (item 49) (pin axis either parallel or perpendicular to V-type upper suspension bracket). If two or more connections are fitted, a corresponding number of V-type upper suspension brackets must be fitted next to each other.

The pin axis of the V-type upper suspension bracket must always be horizontal and parallel to the pin axis of the V-type hinged suspension clamp (item 47) and perpendicular to the suspension rod axis. V-type upper suspension brackets on sloping superstructures must be anchored against movement. If V-type upper suspension brackets are not fitted to steel profile sections, packing plate (item 51) must be used.

**Finish:** galvanized

For further information on **clamp section with V-type upper suspension bracket V** for steel sections with larger flange widths for various flange thicknesses, see technical data 203 072 44.

### 6.7.2 Packing plate for upper suspension bracket

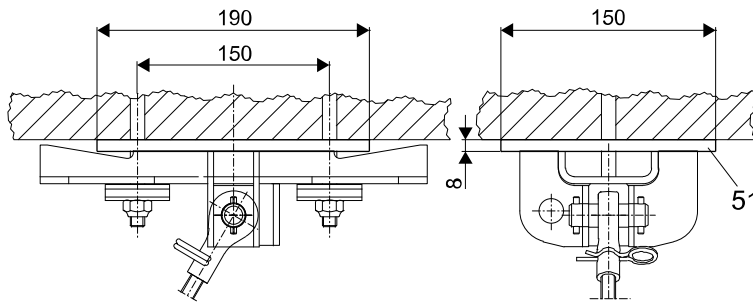

Item	Designation		
51	Packing plate for upper suspension bracket	Weight [kg]	1.79
		Part no.	984 088 44

If the V-type upper suspension bracket is not fitted to steel sections, packing plate (item 51) must be used. This is to ensure that the V-type upper suspension bracket is properly fitted to solid ceilings, ceiling section rails, etc.

### 6.7.3 V-type hinged suspension clamp (item 47)

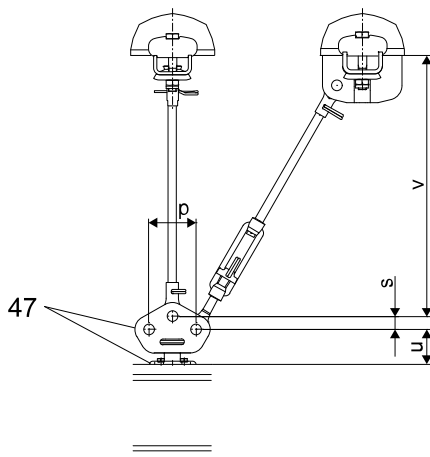

$h_1$  = suspension rod length

Profile	p [mm]	s [mm]	u [mm]	v [mm]
AL12/AL16	60	20	51	$h_1 + 65 \pm 4$
AL18/AL22	90	25	69	$h_1 + 100 \pm 7$

Item	Designation		AL12/AL16	AL18/AL22
47	V-type hinged suspension clamp	Weight [kg]	1.24	2.56
		Part no.	855 160 44	855 166 44
54	Pin with BoClip for third hinged end piece	Weight [kg]	0.08	0.16
		Part no.	851 305 44	851 317 44



### Possible mounting configurations

The V-type hinged suspension clamp (item 47) consists of a suspension clamp, V-type hinge and two pins with spring pins.

The V-type hinged suspension clamp is designed for a maximum of three suspension rod connections (suspension rod strainer or hinged end piece). On a V-type suspension arrangement, the rods are fitted to the outer holes, on a lateral stiffener to the center and one outer hole.

The V-type hinge can be adjusted in the suspension clamp to any angle in relation to the track, however, the pin axis must always be perpendicular to the suspension rod axis. Where three hinged end pieces are used, one additional pin with a BoClip must be ordered.

#### 6.7.4 Spring clip (item 43), suspension rod strainer (item 48) and hinged end piece (item 49)

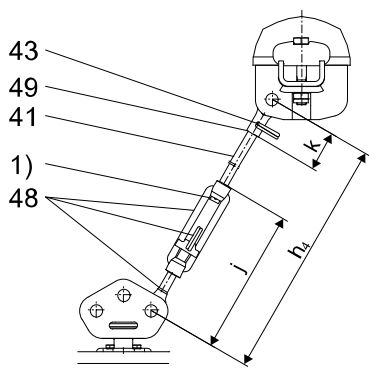

1) No spring clip fitted here

$h_1$  = suspension rod length

Profile	$h_4$ [mm]	$j$ [mm]	$k$ [mm]
AL12/AL16	$h_1 + 155 \pm 30$	$165 \pm 15$	60
AL18/AL22	$h_1 + 220 \pm 40$	$235 \pm 20$	65

Item	Designation		AL12/AL16	AL18/AL22
43	Spring clip	Weight [kg]	0.01	0.02
		Part no.	342 200 99	342 201 99
48	Suspension rod strainer	Weight [kg]	0.29	0.85
		Part no.	980 310 44	984 085 44
49	Hinged end piece	Weight [kg]	0.10	0.30
		Part no.	980 315 44	984 083 44

**Possible mounting configurations**

Suspension rod strainer (item 48) and hinged end piece (item 49) together with one suspension rod connect the upper and lower parts of the V-type suspension fitting/suspension fitting with stiffener/sloping suspension fitting. The suspension rod strainer consists of a strainer nut, hinged end piece with left-hand thread, retaining cap and a spring clip.

If the length of the suspension rods can be determined exactly, the track can also be suspended without a suspension rod strainer. In this case, a hinged end piece (item 49) is used at the top and bottom, and the V-type upper suspension brackets can be pulled apart to level the track.

**Length of the suspension rod thread in the hinged end piece:**

AL12/AL16: 20 mm

AL18/AL22: 25 mm

**Length of the left-hand thread of the hinged end piece and of the suspension rod thread in the strainer nut:**

AL12/AL16: 45 mm

AL18/AL22: 60 mm at full ± adjustment.

One spring clip (item 43) is required for every connection between a hinged end piece (item 49) and suspension rod (item 41). Only the connection between the strainer nut and suspension rod is not provided with a spring clip.

**6.7.5 Wall fixture**

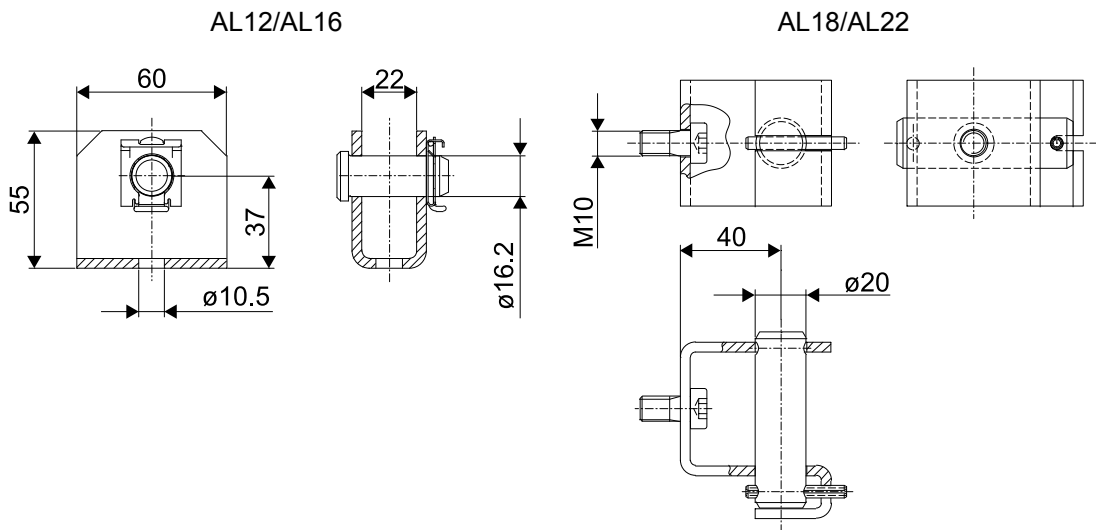

Item	Designation		AL12/AL16	AL18/AL22
34	Hinged block/connector section	Weight [kg]	0.2	0.46
		Part no.	980 272 44	850 399 44
54	Pin with BoClip	Weight [kg]	0.08	-
		Part no.	851 305 44	-

The hinged block/connection block can be used as a wall anchorage for a stiffener arrangement, see [Stiffener \(page 57\)](#).

## 6.8 Determining suspension rod length $h_1$ for V-type suspensions and stiffeners

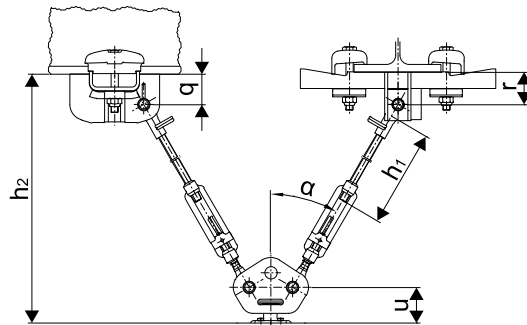

	q	r	u
AL12/AL16	40	45	51
AL18/AL22	55	65	69

Suspension rod length  $h_1$  can be determined depending on:

- AL profile section,
- Steel superstructure alignment,
- Distance between lower edge of steel superstructure and upper edge of AL section (dimension  $h_2$ ),
- Opening angle  $\alpha$ .

The following simplified formulas can be used, since the suspension rod strainer offers a wide range of adjustment.

$$\text{AL12/AL16} \quad \rightarrow \quad h_1 = \{ (h_2 - 95) / \cos \alpha \} - 155$$

$$\text{AL18/AL22} \quad \rightarrow \quad h_1 = \{ (h_2 - 135) / \cos \alpha \} - 220$$

## 7 TROLLEY COMBINATIONS

### 7.1 Single trolleys

The traction resistance of a loaded trolley is <0.2% of the attached load with constant displacement.

Start-up traction resistance is between 0.5% and 0.8% of the attached load depending on the load and time at standstill.

For further information on smooth-running characteristics, see [Design principles \(page 10\)](#).

The permissible load on trolleys is reduced for:

Continuous temperature [°C]	Possible load [%]
-20	50
-15	80
-10 to +40	100
+50	90
+60	75
+70	50

### 7.2 Double trolleys

#### Classic articulated frame

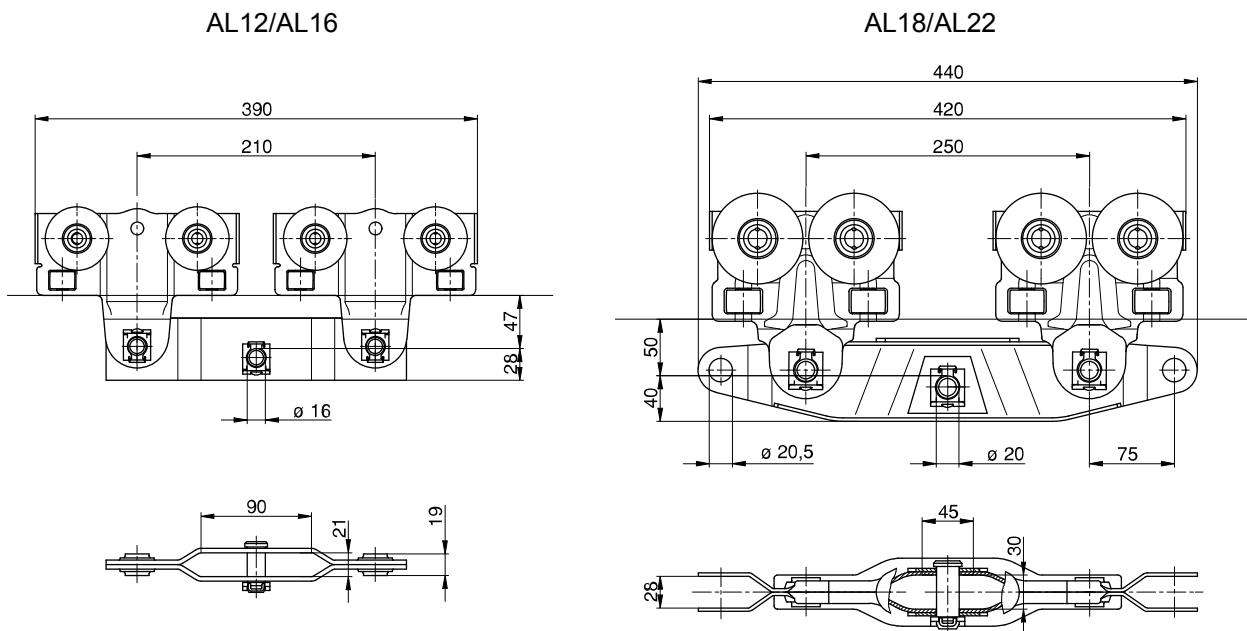

Item	Designation	AL12/AL16			AL18/AL22		
		Max. load [kg]	Weight [kg]	Part no.	Max. load [kg]	Weight [kg]	Part no.
56	Double trolley end carriage, completed (articulated frame + 2 trolleys)	600	3.40	855 422 44	1200	6.95	855 622 44
57	Articulated frame		1.00	980 305 44		2.00	982 305 44

A double trolley is created by joining two trolleys with an articulated frame. Holes drilled in the ends of AL18/AL22 articulated frames are provided for fitting spacer bars and link bars, they are not designed for connecting loads.

**Finish:** black (RAL 9005), steel

Table 3. Wearing parts for single and double trolleys

Item	Designation		AL12/AL16	AL18/AL22
54	Pin with BoClip	Weight [kg]	0.08	0.16
		Part no.	851 305 44	851 317 44
185	Box BoClip D = 16 mm (16 off)	Weight [kg]	0.12	-
		Part no.	980 559 44	-
	Box BoClip D = 20 mm (12 off)	Weight [kg]	-	0.14
		Part no.	-	851 559 44

## 7.3 Load bars for travel on straight tracks for trolleys and cranes with a supporting pin

### 7.3.1 Load bar 600 (items 59, 60)

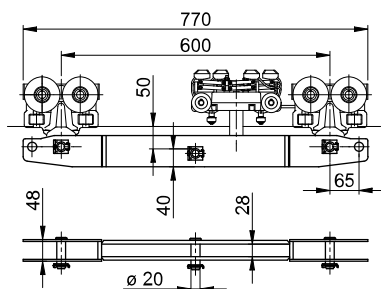

The current collector trolley is protected against collision between the trolleys.

Item	Designation	AL18/AL22		
		Max. load	Weight	Part no.
		[kg]	[kg]	
60	Load bar 600, completed	1200	10.00	855 665 44
59	Load bar 600		5.82	858 600 44

**Finish:** black (RAL 9005)

### 7.3.2 Type A load bar (item 59)

Load bar for crane trolleys (EHK)

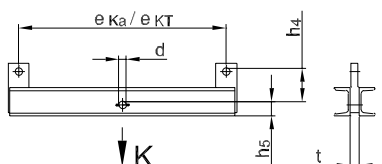

Item	Track	e <sub>KT</sub> [mm]	K <sub>max</sub> [kg]	h <sub>5</sub> [mm]	h <sub>4</sub> [mm]	d [mm]	t [mm]	Weight [kg]	Part no.
59	AL12 AL16	600	780	35	65	20	25	6.43	715 800 46
		1000	770					15.82	715 801 46
		1200						18.66	715 802 46
		1600	760					24.32	715 803 46
		2000						29.99	715 804 46
	AL18	1000	1300	40	72	20	25	16.13	715 821 46
		1200			87			18.96	715 822 46
		1600						29.65	715 823 46
		2000						107	44.24
		AL22			1000			2360	50
	1200		27.94	715 832 46					
	1600		2340	117	45.28	715 833 46			
	2000		2320	137	66.59	715 834 46			

Finish: black (RAL 9005)

## 7.4 Load bars for travel on straight tracks for trolleys and cranes with two supporting pins

### 7.4.1 Type B load bar (item 66)

Load bar for crane trolleys (ZHK)

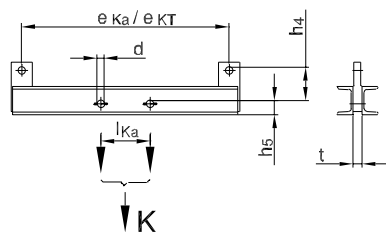

Item	Track	e <sub>KT</sub> [mm]	l <sub>Ka</sub> [mm]	K <sub>max</sub>	h <sub>5</sub> [mm]	h <sub>4</sub> [mm]	d [mm]	t [mm]	Weight [kg]	Part no.						
66	AL12 AL16	1000	550	780	35	65	20	25	9.87	715 811 46						
		1200							11.50	715 812 46						
		1600		760					24.38	715 813 46						
		2000							30.04	715 814 46						
	AL18	1000	550	2370	40	72	20	25	16.18	715 841 46						
			650						715 851 46							
		1200	550						19.02	715 842 46						
			650						715 852 46							
		AL22	1600						550	2350	107	107	20	25	35.81	715 843 46
									650						715 853 46	
	2000	550	2330	127	127	127	20	25	55.34	715 844 46						
									650	715 854 46						

Data required for ordering:

Part no. and l<sub>Ka</sub> in mm.

Finish: black (RAL 9005)

## 7.5 Classic crane end carriages

Rigid crane trolleys make it possible to build parallel-running single and double-girder cranes with a direct connection to the crane girder.

Double-girder crane are fitted with normal crab frames.

Two frames and two crane end carriages are required for each crane.

Link bars, spacer bars or buffer fittings can be connected using single-trolley links or articulated frames (see [Coupling elements and spacer bars \(page 78\)](#) and [Buffers and end stops \(page 82\)](#)).

**Frame and crane end carriage not including trolleys and articulated frames.**

### 7.5.1 Frame for double-girder crane (item 63)

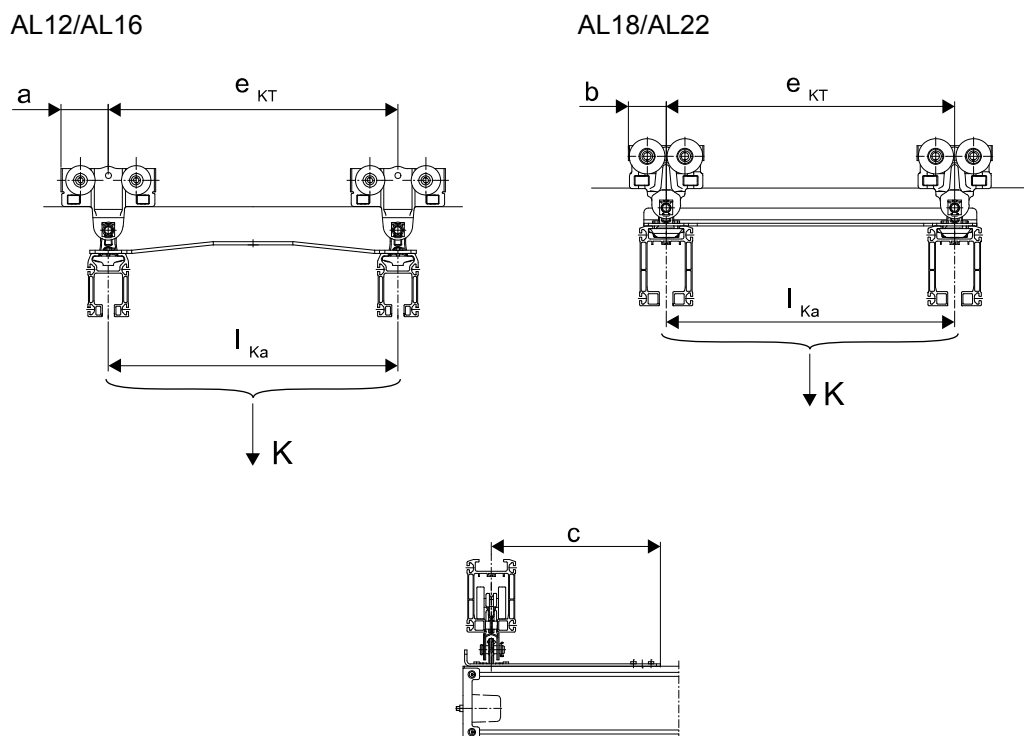

	a	b	c
AL12/AL16	85	85	350
AL18/AL22	90	90	420

Item	Designation	$l_{ka} = e_{KT}$		AL12/AL16	AL18/AL22	
				Max. load		
		[mm]		595 kg	1190 kg	2370 kg
63	Frame for double-girder crane	550	Weight [kg]	4.30	7.10	-
			Part no.	855 181 44	855 183 44	-
		610	Weight [kg]	-	8.60	-
			Part no.	-	715 760 46	-
		650	Weight [kg]	-	-	8.70
			Part no.	-	-	855 185 44
		762	Weight [kg]	-	-	9.30
			Part no.	-	-	715 762 46
		800	Weight [kg]	-	-	-
			Part no.	-	-	-
		915	Weight [kg]	-	-	9.90
			Part no.	-	-	715 764 46
		1000	Weight [kg]	-	-	10.30
			Part no.	-	-	715 766 46

**7.5.2 Rigid single-girder crane end carriage (item 62)**

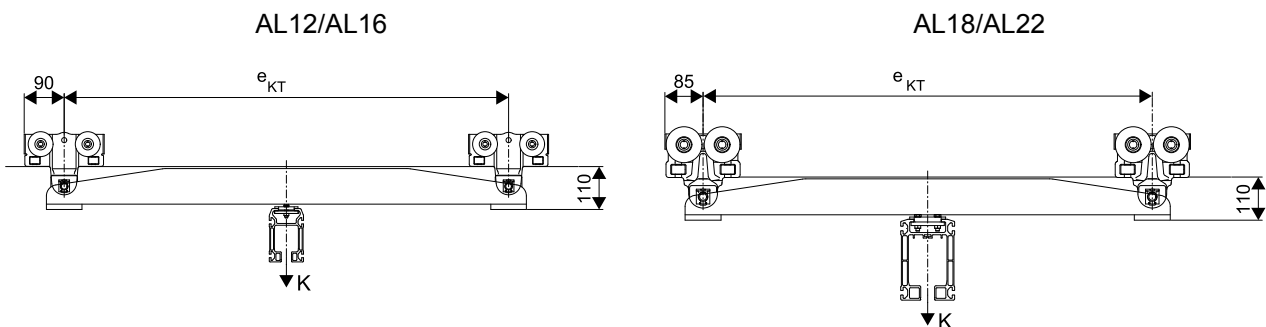

Item	Designation	$e_{KT}$ [mm]	Max. load K [kg]	AL12/AL16		AL18/AL22		
				Weight [kg]	Part no.	Max. load K [kg]	Weight [kg]	Part no.
62	Rigid single-girder crane end carriage	1000	580	14.00	517 672 46	1170	25.00	517 678 46

**Length of stiffener on the crane:**

AL12/AL16: **340 mm;**

AL18/AL22: **640 mm.**

Check trolley loads.

**Finish:** black (RAL 9005), steel



# 8 DOUBLE-RAIL CRAB

Crab frame (item 78)

AL12

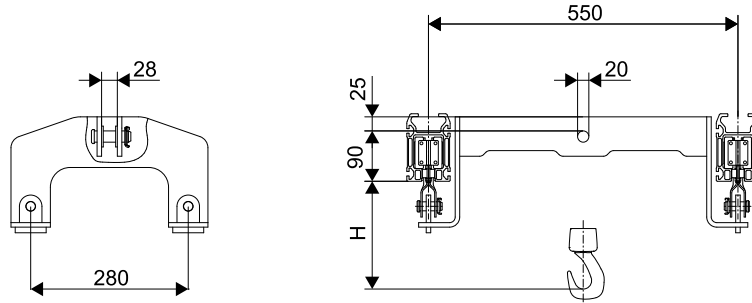

AL16

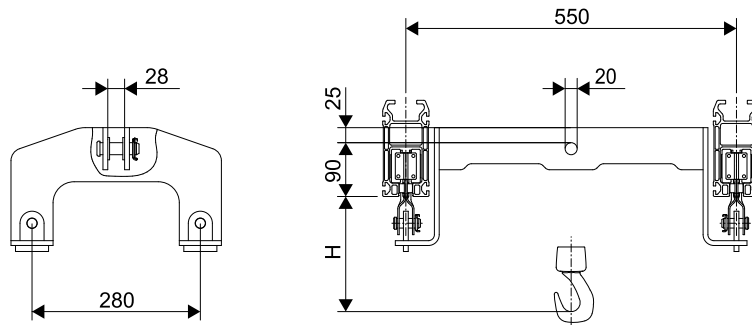

AL18

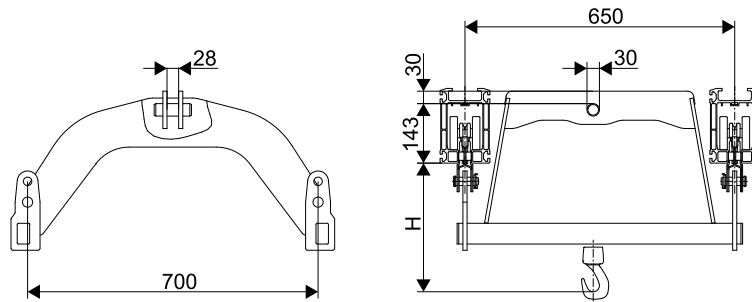

AL22

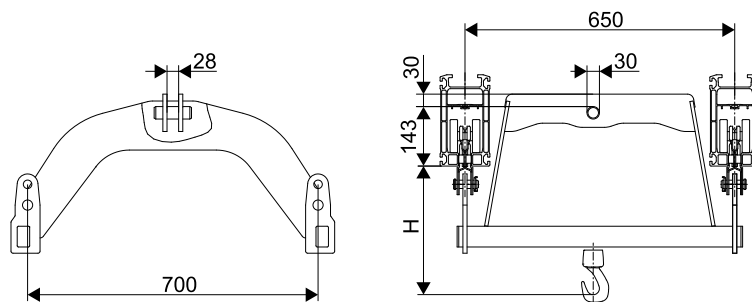

Item	Designation	AL12/AL16			AL18/AL22			AL22		
		Max. load K [kg]	Weight [kg]	Part no.	Max. load K [kg]	Weight [kg]	Part no.	Max. load K [kg]	Weight [kg]	Part no.
78	Crab frame	600	8.90	980 602 44	1200	16.40	858 110 44	2200	25.24	855 675 44

AL crab frames fitted with four trolleys and the hoist form a double-rail crab for double-girder cranes.

The crab frame can pass under crane end carriages.

Travel drives are fitted outside the crab frame for AL12/AL16, and can be fitted both inside and outside the crab frame for AL18/AL22. The drive motor must face outwards and the hoist motor must face the drive.

All hoists must be used with the long suspension eye.

**Finish:** black (RAL 9005), steel

*Table 4. Wearing parts on the hoist support pin*

Item	Designation		
54	Pin with BoClip	Weight [kg]	0.18
		Part no.	851 318 44
185	Box BoClip D = 20 mm (12 off)	Weight [kg]	0.14
		Part no.	851 559 44

# 9 CRANE SUSPENSION EYE

## Crane suspension eye (item 75)

AL12/AL16

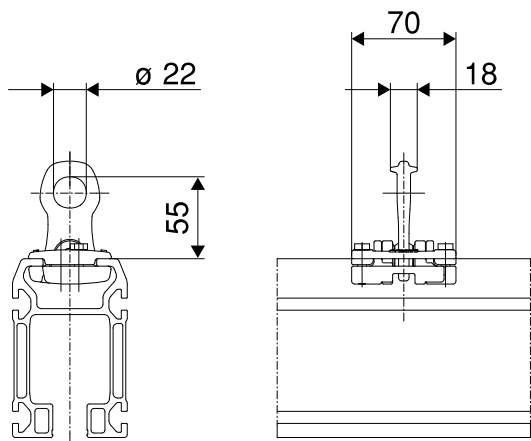

AL16

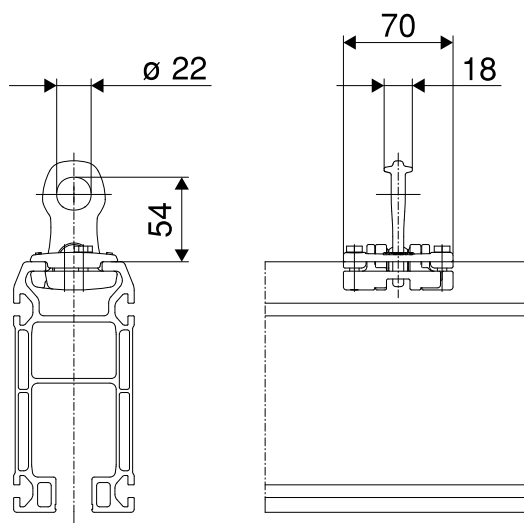

AL18

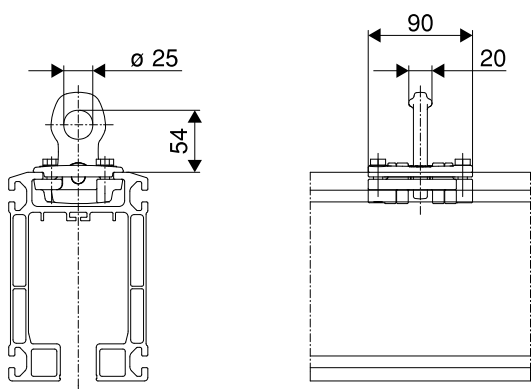

AL22

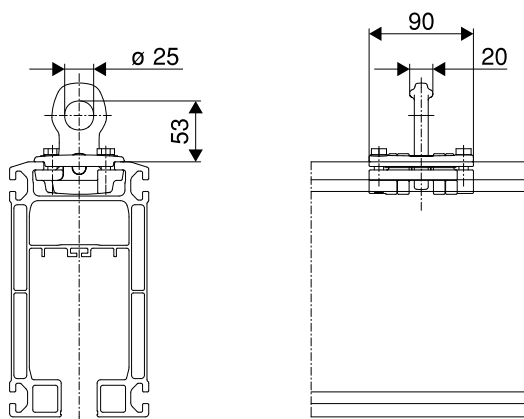

Item	Designation	AL12/AL16			AL18/AL22		
		Max. load K [kg]	Weight [kg]	Part no.	Max. load K [kg]	Weight [kg]	Part no.
75	Crane suspension eye	600	0.42	855 455 44	1400	0.84	855 655 44

The crane suspension connects crane girders with the trolley or the articulated frame of the runway girder.

Maintenance-free pivot bearings are fitted in the lower pivot point.

**Finish:** galvanized steel

# 10 TRAVEL DRIVES FOR CRABS AND CRANES

## 10.1 RF 125 friction-wheel travel drive

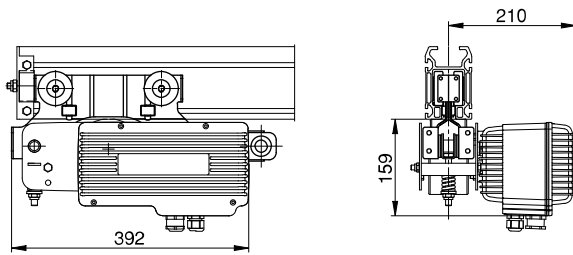

### Technical data

Table 5. TD E22-C BL DC motor with worm gearbox

Travel speed	Output	ED	Voltage	Frequency	Max. displaceable lifted load incl. dead load	Weight	Part no.
[m/min]	[W]	[%]	[V]	[Hz]	[kg]	[kg]	
7/27 <sup>1)</sup>	50/200	20/40	3 ~ 220–480	50/60	2200	6.9	716 904 45

<sup>1)</sup> By programming the parameters can be changed to:

- max. 8/33 m/min with partial load
- min. 3/16 m/min

The RF 125 friction-wheel travel drive is a drive unit specially developed for crane requirements with regulated acceleration and braking for loads up to 2000 kg.

**Finish:** black (RAL 9005)

### 10.1.1 Drive data

The output of the pneumatic travel motor is transmitted to the bottom flange of the rail by means of a friction wheel. The friction wheel is pressed against the bottom flange of the rail by means of a pressure spring.

A permanent-field DC worm geared motor serves as the drive motor.

The speed of DC motors can be controlled very well, enabling smooth acceleration and braking of the drive to be achieved. This facilitates travel with little sway.

The worm geared motor is of self-braking design, which eliminates the need for a holding brake.

### 10.1.2 Control system

The control board features a wide voltage range input (220–480 V/50/60 Hz). The line voltage supplies a regulated link. The motor is supplied from the link by a PWM power module. Ramps are output for start-up and braking. The moving motor is braked with electric control and stopped by a short circuit of the armature winding.

The control system includes the following features as standard:

- Plug connections for all inputs and outputs;
- Line voltage relayed to the chain hoist;
- Limit switch inputs;
- Fast-to-slow limit switch inputs;
- 7-segment display visible through a window from the outside for operating status, error messages, parameter programming;
- Programmable parameters for speed, acceleration, etc.;

- Temperature monitoring and cut-off on overheating;
- Control with tri-state signals (half-wave evaluation) or with PWM signals
- Optimum long travel characteristics thanks to master/slave operation with up to 3 drives (1 master, 2 slaves)
- Simple parameter programming by control pendant or by separately available keypad terminal.

**10.1.3 RF 125 rocker (item 135)**

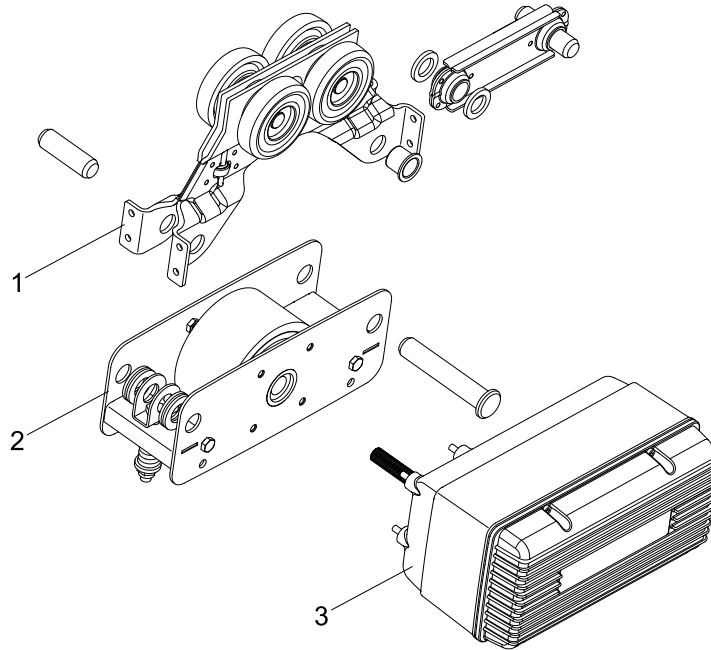

- 1. Tractor trolley
- 2. RF 125 rocker
- 3. E 22 travel drive

Item	Designation		
135	RF 125 rocker	Weight [kg]	4.6
		Part no.	858 245 44

**Finish:** black (RAL 9005); galvanized

**10.1.4 Possible mounting configurations**

RF 125 friction-wheel travel drives can be fitted in various ways, whereby the following must be considered (see also example for ordering):

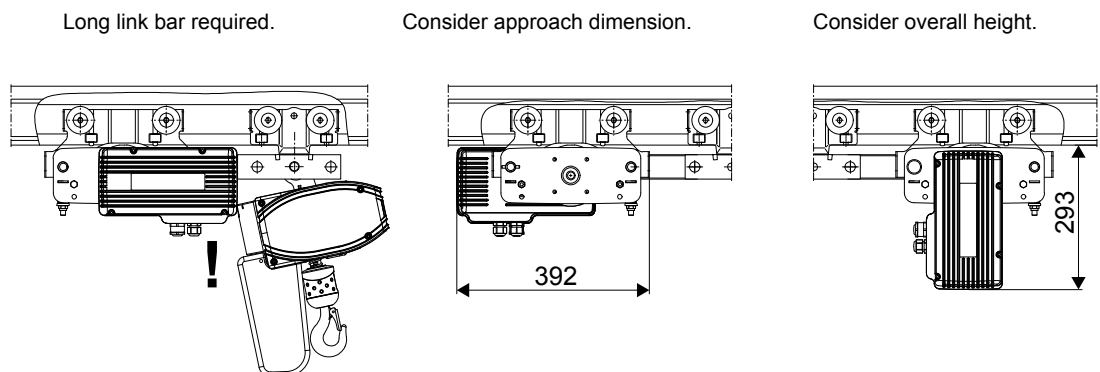

Example for ordering RF 125

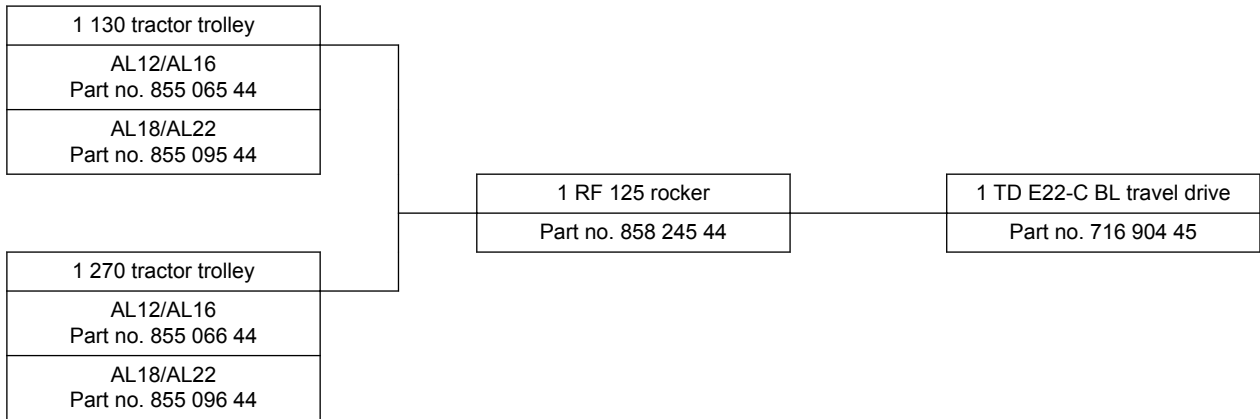

## 10.2 Travel limit switches

### RF 125 limit switch fitting (items 141, 142)

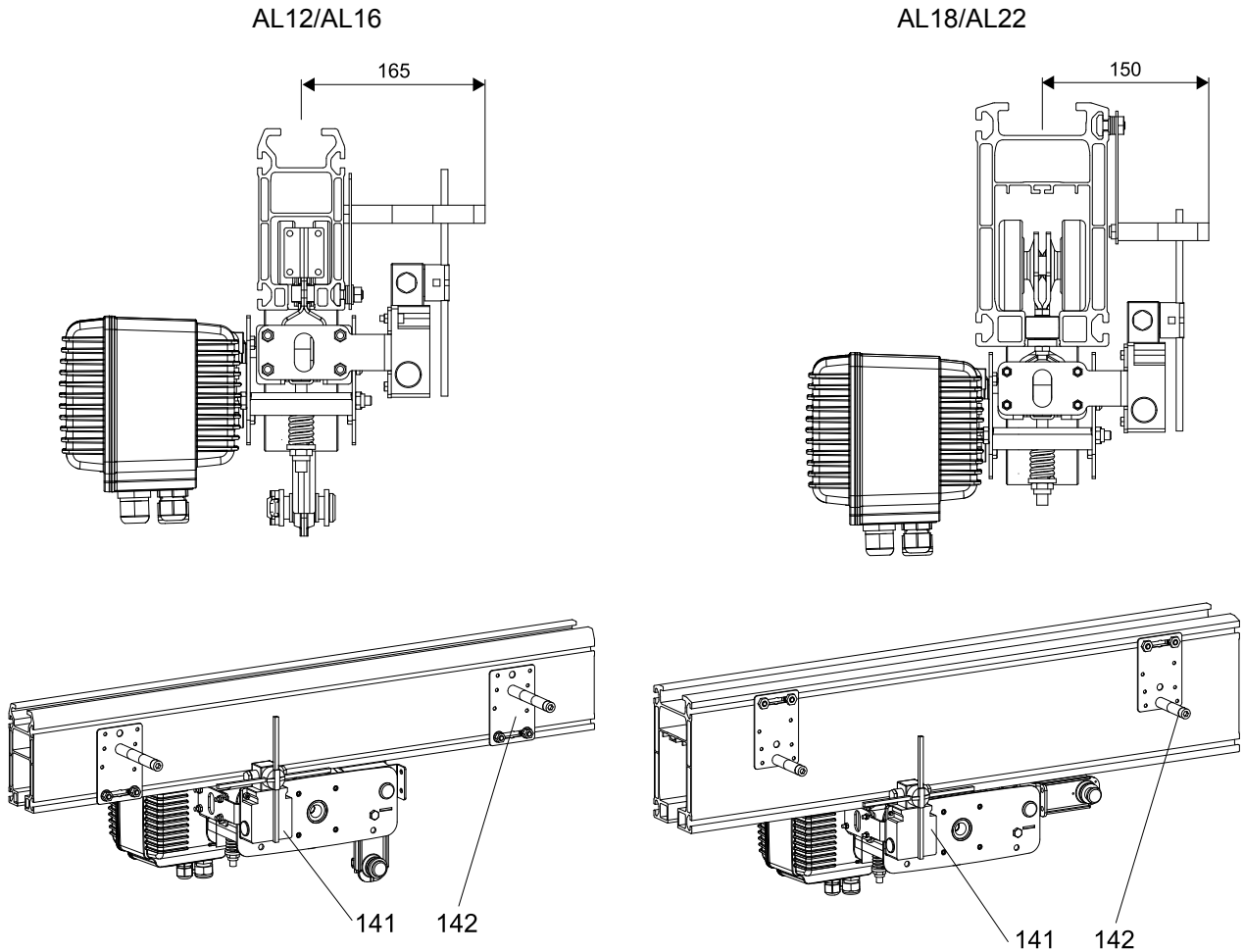

Item	Designation		AL12/AL16	AL18/AL22
141	Limit switch, cpl.	Weight [kg]	0.85	0.85
		Part no.	858 351 44	858 351 44
142	Switching vane, cpl. (only for single-stage switching for AL22)	Weight [kg]	0.39	0.29
		Part no.	517 964 46	517 965 46

Limit switch fittings are designed to be used with RF 125 travel drives on ProfileMaster PLUS AL systems. They can be used for reliable switch-over from fast to slow travel, or from slow travel to the stop function.

This is utilized when travel against the limit stops needs to be avoided.

#### Crane applications

When a limit switch is used with a crane long-travel drive, the signal from the switch is also sent to the second travel drive.

**Contents**

The limit switch cpl. includes the switch, the rail fitting and the electric cable to the drive.

The switching vane cpl. includes two switching vanes to actuate the switch including the fittings for attachment to the rail.

**Finish:** galvanized



## 11 TROLLEYS FOR TRAVEL DRIVES

RF trolley (item 69)

165 trolley coupling (item 71)

AL12/AL16/AL18/AL22 with RF 125

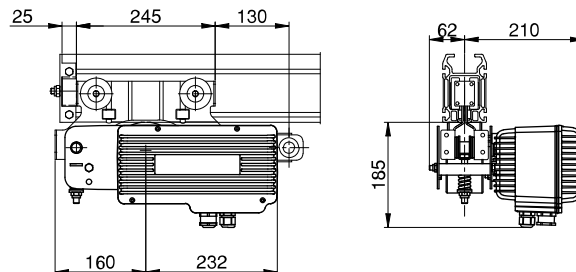

Item	Designation		AL12/AL16	AL18/AL22
69	130 trolley	Weight [kg]	3.0	4.0
		Part no.	855 251 44	855 095 44
	270 trolley	Weight [kg]	3.5	4.3
		Part no.	855 252 44	855 096 44
71	165 trolley coupling	Weight [kg]	-	0.3
		Part no.	-	855 142 44

The trolleys shown are suitable for the following drives:

Trolley for AL12/AL16: RF 125

Trolley for AL18/AL22: RF 125

**Finish:** black (RAL 9005)

## 12 COUPLING ELEMENTS AND SPACER BARS

Single-trolley links, hinged blocks, link bars or spacer bars can be used to connect trolleys and travel drives for any trolley combinations.

The travel drive must always be connected to the load trolley.

### 12.1 Link for single trolley (item 61)

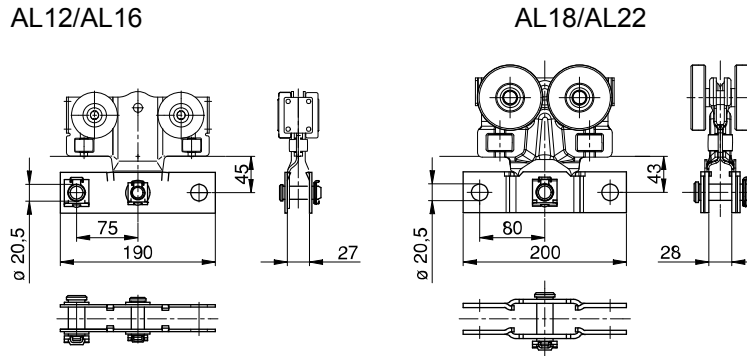

Item	Designation		AL12/AL16	AL18/AL22
61	Link for single trolley	Weight [kg]	0.7	0.8
		Part no.	855 070 44	855 205 44

The link provides an additional means for connecting spacer bars, buffers and travel drives to trolleys with a suspended load.

**Finish:** black (RAL 9005), steel

### 12.2 165 trolley coupling/long link bar

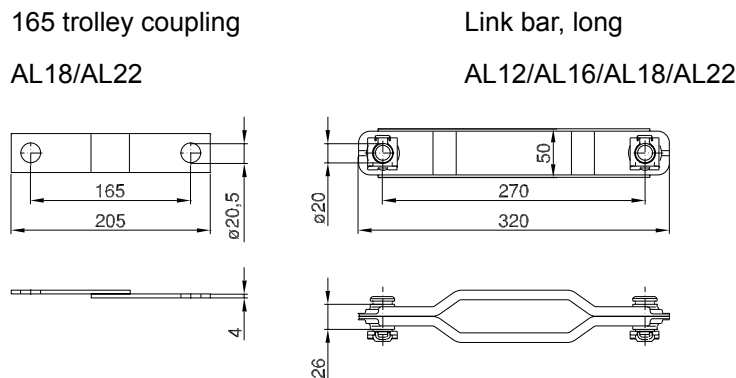

Item	Designation		AL12/AL16	AL18/AL22
71	165 trolley coupling	Weight [kg]	-	0.3
		Part no.	-	855 142 44
	Link bar, long	Weight [kg]	0.9	0.9
		Part no.	982 345 44	982 345 44

165 trolley couplings are used to connect friction wheel units in AL18/AL22 crab frames.

Long link bars can be used for any trolley combinations and special applications.

**Finish:** black (RAL 9005), steel

### 12.3 Articulated spacer bars (items 72, 73)

#### Examples

Spacer bar on single trolley

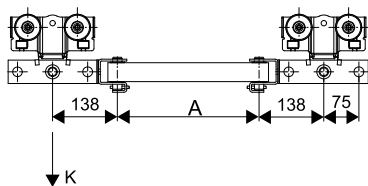

On double trolley

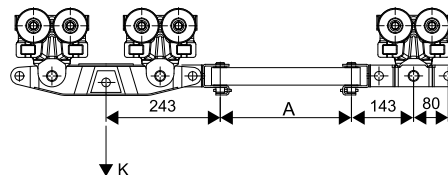
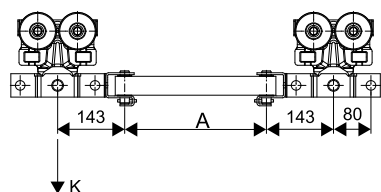
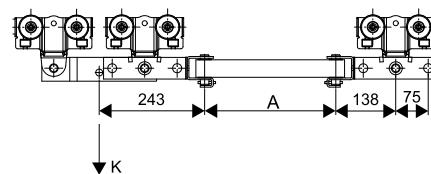

On trolley for RF (one or both sides)

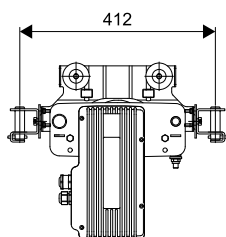

**Components**

Hinged block

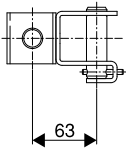

RF hinged block

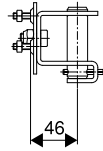

Connector section

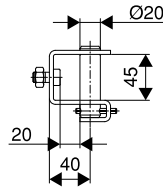

Spacer bar for hinged blocks

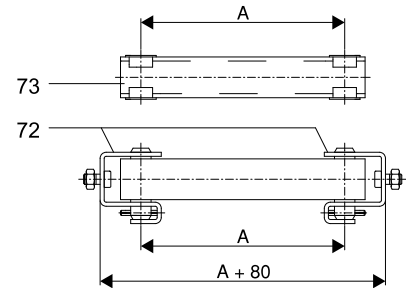

Item	Designation	Length A min.	Length A max.		
72	Hinged block			Weight [kg]	0.75
				Part no.	982 402 44
	RF hinged block			Weight [kg]	0.65
				Part no.	982 399 44
	Connector section			Weight [kg]	0.46
				Part no.	850 399 44
73	Spacer bar for hinged blocks	70	2500	Weight [kg]	5.0/m
				Part no.	850 337 44

Spacer bars are used to distribute loads safely by separating several single or double-girder cranes running on the same crane runway. The deadweight of the spacer bar must be included in load K when selecting the crane runway. Current collector trolleys or RF travel drives must always be connected to the load trolley.

**Finish:** black metal parts (RAL 9005); galvanized pins, nuts and bolts

**Example for ordering:**

2 off hinged block, order no. 982 402 44

1 off spacer bar for hinged blocks, A = 700 mm, order no. 850 337 44

**12.4 Spacer bars for straight track, AL18/AL22**

Spacer bar with one open end

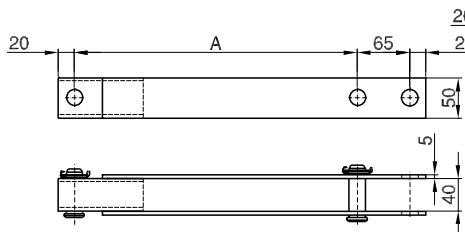

Spacer bar with two open ends

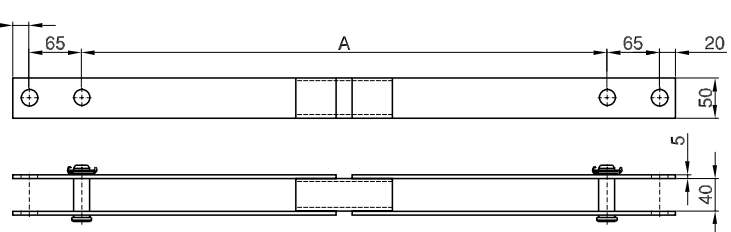

## Examples with two open ends

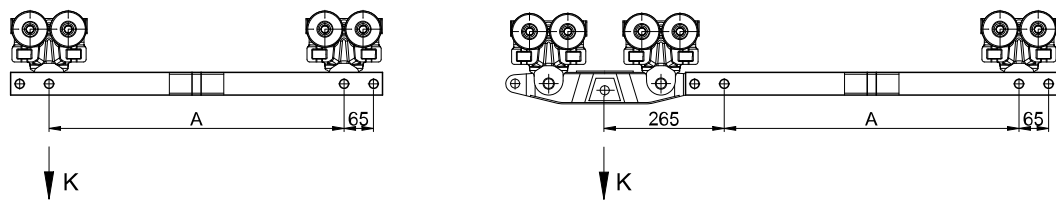

Item	Designation	Fitted to	Dimensions		Weight [kg]	Part no.
			A min.	A max.		
76	Spacer bar with one open end	Spacer bar, trolley	350	3500	4.8/m + 0.5	Standard drawing
	Spacer bar with two open ends	Single trolley, articulated frame	650	3500	4.8/m + 1.0	Standard drawing

Spacer bars can be used to distribute loads safely by separating several single or double-girder cranes running on the same track.

The dead weight of the spacer bar must be included in load K when selecting the monorail.

**Finish:** black metal parts (RAL 9005); galvanized pins, nuts and bolts

**Examples for ordering:**

2 off spacer bar with one open end, A = 3000 mm

2 off spacer bar with two open ends, A = 2800 mm

## 13 BUFFERS AND END STOPS

Limit stops with rubber buffers, end caps with rubber buffers, cellular plastic buffers or shock absorbers can be used to limit long and cross-travel motions in AL installations.

To lessen the impact forces of several cranes on the same track and/or to reduce the noise of impact, buffers should be provided between the trolleys or cranes.

For push travel hoist trolleys and cranes, rubber buffers can be used for normal operating conditions, and cellular plastic buffers for a high degree of impact absorption (buffer against buffer plate).

Electrically or pneumatically driven hoists and cranes can be fitted with cellular plastic buffers (cellular plastic buffer against buffer plate). Where travel speeds exceed 21 m/min, the ends facing each other must be fitted with identical buffers (cellular plastic buffer against cellular plastic buffer).

### 13.1 Buffers on crabs and cranes outside the profile section

**Rubber stop (item 98)**

**Buffer fitting (cellular plastic) (item 98)**

**Buffer plate (item 98)**

**RF buffer fitting (cellular plastic) (item 98)**

**RF buffer plate (item 98)**

**AL buffer components**

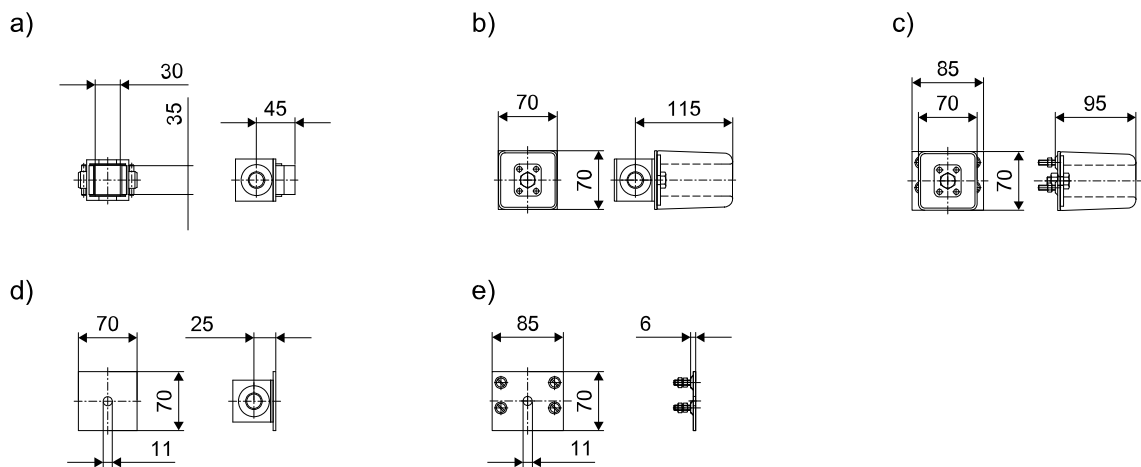

Item	Designation	Fitted to	Weight [kg]	Part no.
98	Rubber end stop	Single-trolley link, articulated frame, spacer bar with two open ends, spacer bar with one open end	0.44	982 395 44
	Buffer fitting (cellular plastic)		0.80	982 378 44
	Buffer plate		0.49	982 377 44
	RF buffer fitting (cellular plastic)	RF 125 trolley	0.45	982 375 44
	RF buffer plate		0.17	982 374 44

**AL buffer examples**

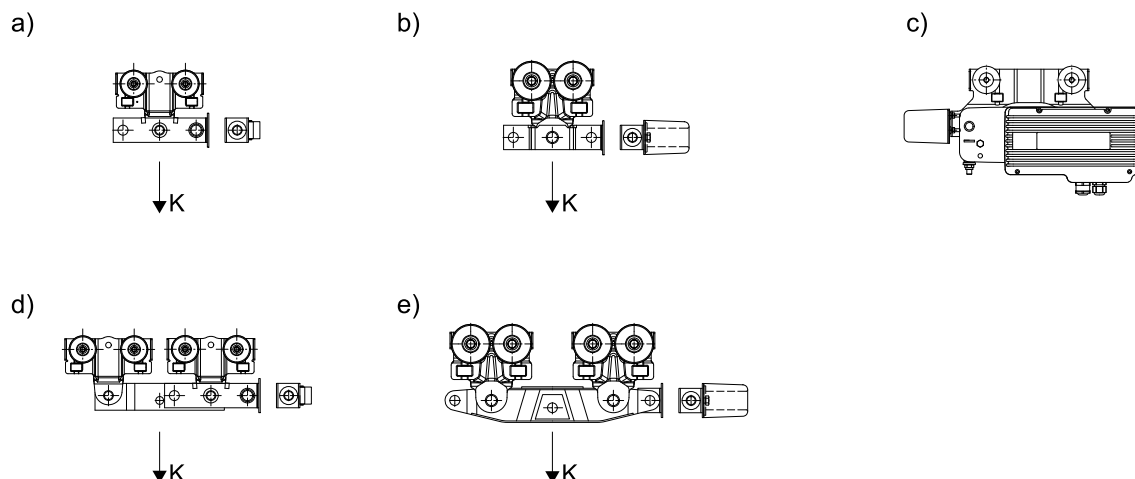

a)	Buffer plate or buffer fitted to AL12/AL16 single-trolley link
b)	Buffer plate or buffer fitted to AL18/AL22 single-trolley link
c)	RF buffer fitted to RF trolley
d)	Buffer plate or buffer fitted to AL12/AL16 double-trolley link
e)	Buffer plate or buffer fitted to AL18/AL22 articulated frame

**13.2 Buffer on AL18/AL22 single trolley inside the profile section**

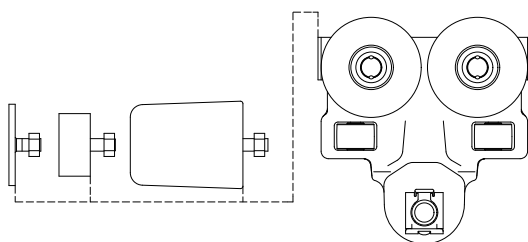

The following parts can be attached direct to AL18/AL22 single trolleys:

Item	Designation		AL18/AL22
98	Stop plate	Weight [kg]	0.13
		Part no.	855 670 44
	Rubber buffer	Weight [kg]	0.10
		Part no.	855 062 44
	Cellular plastic buffer	Weight [kg]	0.25
		Part no.	855 695 44

## 14 POWER SUPPLY TO CRABS AND CRANES

### 14.1 Trailing cable, general information

A cable (4 x 1.5) running on cable sliders and larger or several cables running on cable trolleys in the ProfileMaster PLUS AL section is the most economical power supply system.

Trailing cable with cable slider

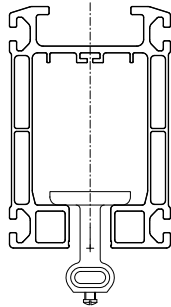

Trailing cable with cable trolley

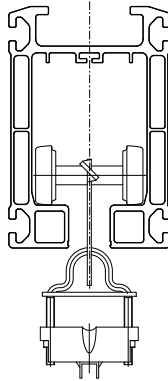

#### Runways

Cable sliders are used for one cable on tracks with simple electric power supplies to the trolley or to the crane.

Cable trolleys should be used for longer tracks, electric long and cross-travel drives and when flat cables with outside dimensions greater than 8 mm x 19 mm or when several flat cables are used.

#### Cable length

The required cable length is calculated as follows:

Track and crane girder length (m) x 1.2 + supply cable length (m)

#### Number of cable sliders or cable trolleys

The quantity of cable sliders or cable trolleys required for a crane or track must be calculated taking into consideration cable sag and track or crane girder length.

Max. trailing cable length with cable sliders: 30 m

Max. trailing cable length with cable trolleys: 50 m

Required quantity of cable carriers n:

$$n = (\text{track or crane girder length [m]} / \text{cable sag [m]} \times 2) - 1$$

#### Approach dimension

The approach dimension of the crane or travelling hoist is increased by the distance required for close accumulation of cable sliders and cable trolleys. Install an internal buffer stop to protect the accumulated cable carriers.

#### Two cranes on one track

If two crane girders operate on one crane runway, power supply can be provided via one flat cable for each of them from opposite ends of the track.



**More than two cranes on one track**

Power cannot be supplied by flat cable if more than two crane girders operate on one track. In these cases, power must be supplied via an internal conductor line ([AL-R components \(page 42\)](#)).

**14.2 Trailing cable, components and fittings**

**14.2.1 Rail end cable clamp (item 83), flat cable with PE (item 84), cable slider (item 85) and cable trolley (item 86)**

AL12/AL16/AL18/AL22

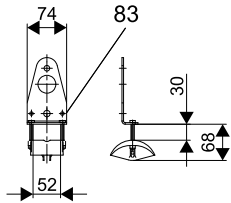

AL12/AL16

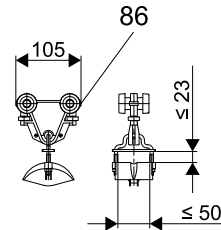

AL18/AL22

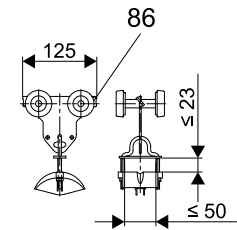

AL12/AL16

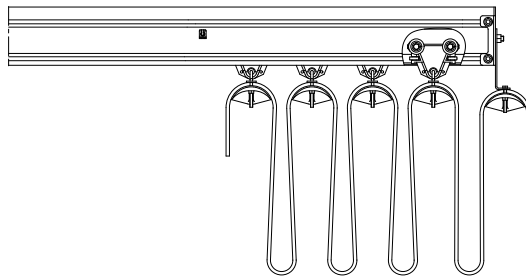

AL18/AL22

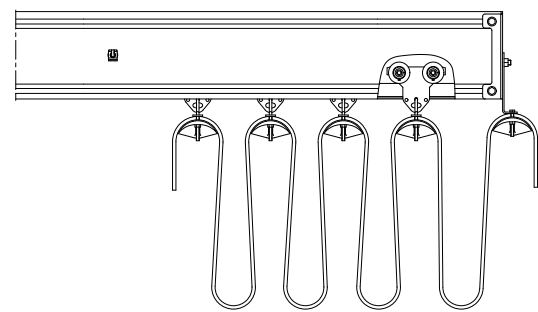

Item	Designation	No. of conductors x rated cross-section [mm <sup>2</sup> ]	External dimensions [mm]	AL12/AL16		AL18/AL22	
				Weight [kg]	Part no.	Weight [kg]	Part no.
83	Rail end clamp			0.23	855 220 44	0.23	855 220 44
84	Flat cable with PE	4 x 1.5	19 x 8	0.21/m	471 352 44	0.21/m	471 352 44
		4 x 2.5	21 x 8	0.26/m	504 208 44	0.26/m	504 208 44
		8 x 1.5	33 x 8	0.35/m	504 226 44	0.35/m	504 226 44
		13 x 1.5	31 x 12	0.55/m	895 171 44	0.55/m	895 171 44
85	Cable slider	Only for 4 x 1.5 and 4 x 2.5 flat cable		0.03	980 759 44	0.04	851 690 44
86	Cable trolley	-		0.22	982 470 44	0.50	855 085 44

Rail end cable clamps are bolted to the end cap with buffer. This provides strain relief of the flat cable to the terminal box and a favorable fixing point for the cable between the crane girder and track girder.

The plastic-sheathed flat cable (cold-resistant) can be used in buildings with a dry or humid atmosphere. Flat cable is flexible in one plane.

Cable sliders with a cable locking screw are suitable for one flat cable with maximum external dimensions of 22 mm x 8 mm. They are made of temperature-resistant plastic.

Cable trolleys can be used to support cables, compressed air or water hoses. Additional holes are provided for attaching strain relief cords.

Temperature range for flat cable, slider and cable trolley: -20 °C to +70 °C.

**Finish:**

- Rail end cable clamp: galvanized
- Cable slider: plain plastic
- Clamping plate: black plastic
- AL12/AL16 cable trolley: black plastic
- AL18/AL22 cable trolley: galvanized

**14.2.2 Crane girder cable clamp (item 80)**

AL12/AL16

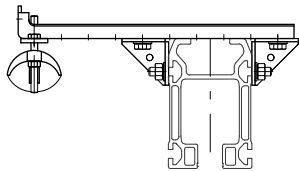

AL18/AL22

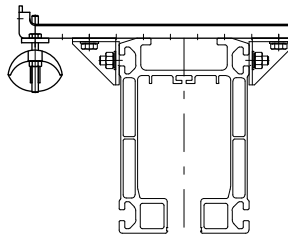

Item	Designation		
80	Crane girder cable clamp	Weight [kg]	0.6
		Part no.	855 106 44

Crane bridge cable clamps are used for push-travel single/double-girder cranes to prevent the flat cable running from the crane runway to the crane girder from being subjected to side pull.

**14.2.3 Crab frame cable clamp (item 81)**

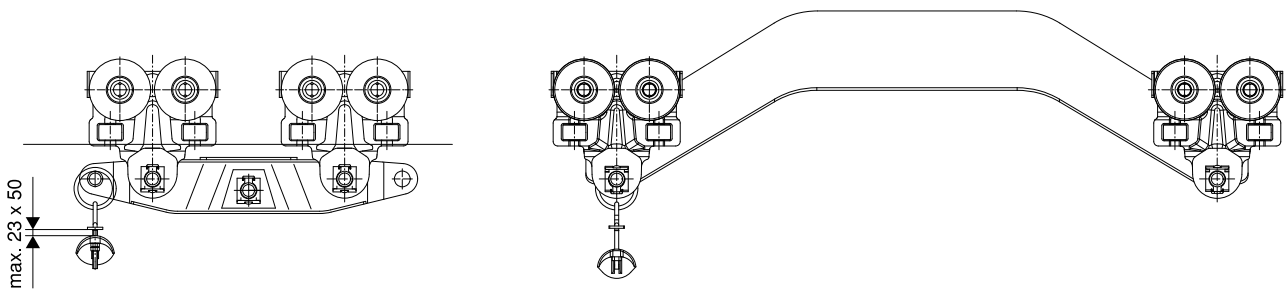

Item	Designation		
81	Crab frame cable clamp	Weight [kg]	0.1
		Part no.	982 577 44

Crab frame cable clamps are suspended from the trolleys of push-travel crab frames to relieve the pull on the hoist terminals.

### 14.2.4 RF trolley cable clamp (item 82)

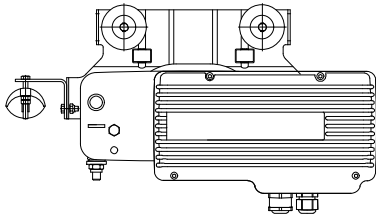

Item	Designation		
82	RF trolley cable clamp	Weight [kg]	0.6
		Part no.	982 578 44

RF trolley cable clamps are fitted to electric-travel hoists/cranes to relieve the pull on the terminals.

### 14.3 Round cable and crane drive connection

Item	Designation		
91	Clip for round cable	Weight [kg]	—
		Part no.	982 124 44
92	3 x 0.5 mm <sup>2</sup> round cable	Weight [kg]	0.042
		Part no.	894 725 44
	4 x 1.5 mm <sup>2</sup> round cable, 1 kV	Weight [kg]	0.109
		Part no.	471 954 44
	7 x 1.5 mm <sup>2</sup> round cable, 1 kV	Weight [kg]	0.178
		Part no.	471 957 44
	8 x 1.5 mm <sup>2</sup> round cable, 500 V	Weight [kg]	0.250
		Part no.	894 136 44
	10 x 1.5 mm <sup>2</sup> round cable, 1 kV	Weight [kg]	0.388
		Part no.	471 960 44

A round cable has to be laid along the crane girder to complete the electric connection between the two travel drives on the track girder for electric-travel cranes.

If an RF 125 is used with TD E22-C BL:

- To connect the crane bridge enclosure with the (master) drive:
  - One 8x1.5 mm<sup>2</sup> round cable
- To connect both drives (master/slave):
  - One 4x1.5 mm<sup>2</sup> round cable and one 3x0.5 mm<sup>2</sup> round cable

Required cable length to connect the two drives:

Crane span dimension  $l_{kr} + 2.5$  m.

The round cable is placed in the upper part of the profile section.

### 14.4 Mains connection switch/isolating switch (item 88)

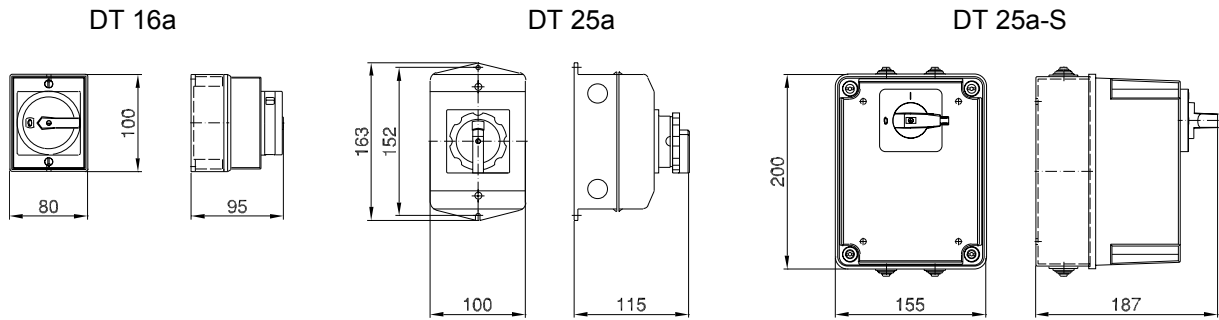

Item	Designation	Size	Voltage [V]	Current [A]		
88	Load isolating switch	DT 16a	≤ 500	Max. 20	Weight [kg]	0.32
					Part no.	575 479 44
		DT 25a	≤ 690		Weight [kg]	0.40
				Max. 25	Part no.	575 480 44
		DT 25a-S			Weight [kg]	1.41
					Part no.	473 037 44

Table 6. Fuse links and inserts for DT 25a-S

Rated current [A]	D fuse link, delayed action Part no.	D screw-in adapter for fuse insert Part no.
6	451 663 99	504 905 99
10	451 643 99	504 906 99
16	451 644 99	504 907 99
20	451 645 99	504 908 99
25	451 646 99	504 909 99

Switch-isolators are suitable for use as mains connection or isolating switches.

Mains connection switch: stationary switch-isolator for a crane installation with one or more cranes.

Isolating switch: on-board switch-isolator on cranes on a common power supply line (conductor line).

Switch-isolators can be locked in the OFF (0) position against unauthorized restoration of the power supply by up to three padlocks.

Two M20 x 1.5 cable entries are available. IP 55 enclosure.

DT 16a switch-isolator without fuses,

DT 25a switch-isolator without fuses,

DT 25a-S switch-isolator with fuse base for 3 fuses.

### 14.5 Terminal box (item 94)

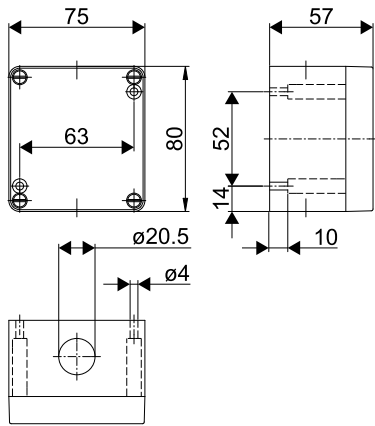

Item	Designation		
94	Terminal box	Weight [kg]	0.40
		Part no.	504 650 44

A terminal box must be provided as the junction with the fixed round cable when flat cables are used to supply power to AL equipment.

For cable sets, see [Cable union sets \(items 190, 191\) \(page 93\)](#).

**Finish:** aluminum enclosure with 6 modular spring-loaded terminals (grey) up to (2.5 mm<sup>2</sup>) fitted on mounting rail, light grey (RAL 7035)

### 14.6 Mounting brackets for switches and terminal boxes

#### 14.6.1 Mounting bracket for terminal box (item 92)

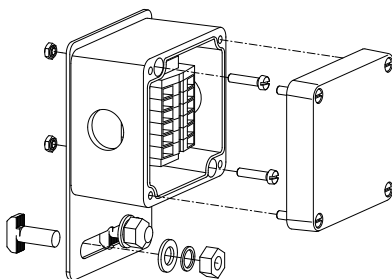
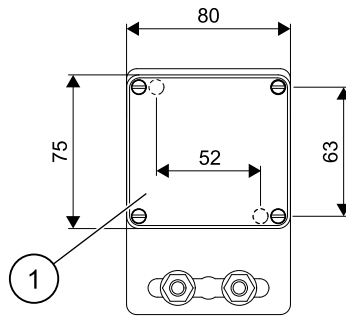

1. Terminal box 504 650 44

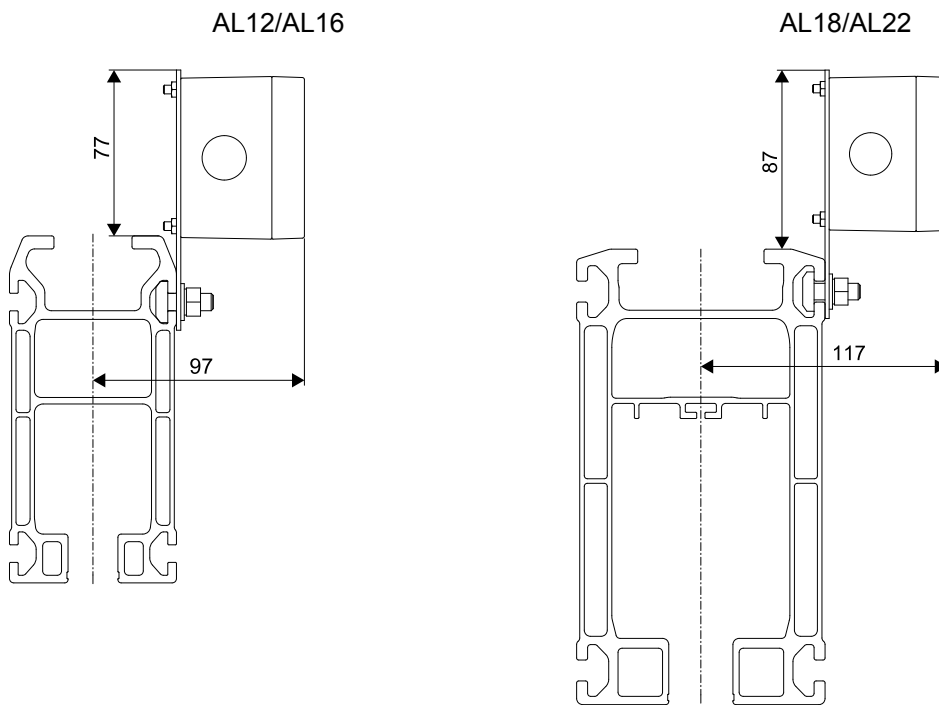

Item	Designation		
92	Mounting bracket for terminal box	Weight [kg]	0.17
		Part no.	855 215 44

Finish: galvanized

### 14.6.2 Mounting bracket for enclosure on RF 125 (item 92)

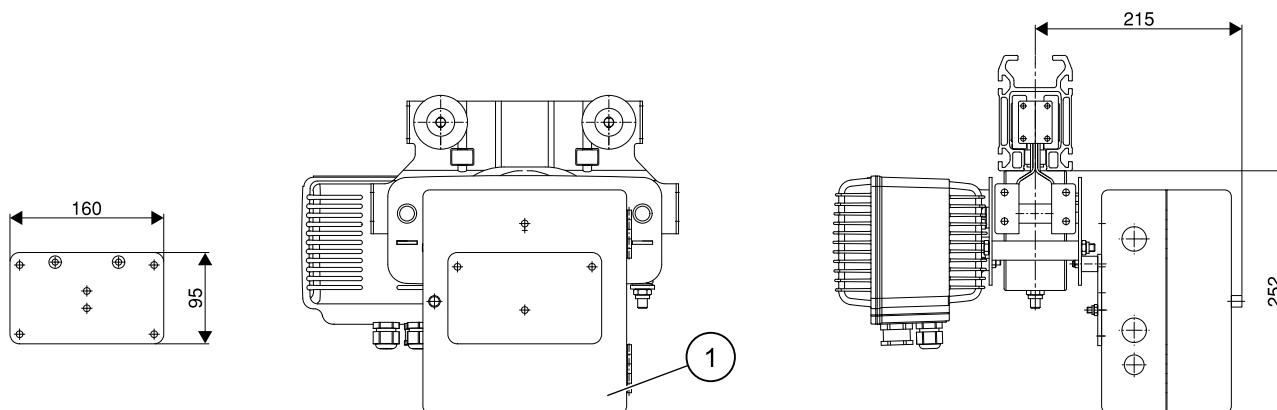

1. Enclosure, order no. 772 407 45

Item	Designation		
92	RF 125 enclosure mounting bracket	Weight [kg]	0.6
		Part no.	851 533 44

The mounting bracket is used to attach the enclosure, order no. 772 407 45.

Finish: black

### 14.6.3 Attachment bracket (item 93)

Small attachment bracket  
for a, b

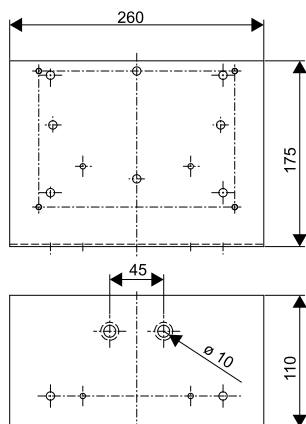

Item	Designation	Weight [kg]	Part no.
93	Small attachment bracket	0.9	851 222 44

Item	Designation	Part no.
a	Mains connection/isolating switch	DT 16 a
b		DT 25 a
		DT 25 a-S

### 14.6.4 Bracket for isolating switch (item 90)

AL12/AL16/AL18/AL22

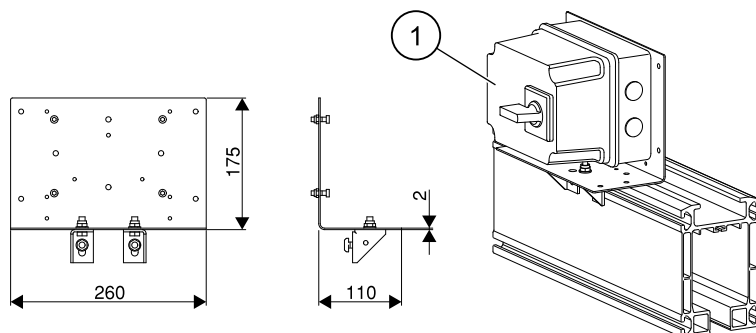

1. DT 25a-S

Item	Designation	Weight [kg]	Part no.
90	Bracket for isolating switch	0.7	855 152 44

The bracket for isolating switches can be used to attach isolating switches and terminal boxes. See small mounting bracket for possible connections.

**Finish:** galvanized

## 15 PROFILEMASTER PLUS AL STANDARD ELECTRIC EQUIPMENT

### 15.1 General

A control system with contactor control or a frequency inverter is used depending on the hoist unit.

The chain hoists have 24 V AC or 48 V AC control voltage.

#### Conversion

Systems can be converted to wireless controls.

#### Electromagnetic compatibility (EMC)

The equipment complies in full with the provisions of the EC EMC Directives.

#### Regulations

All component parts and assemblies fully comply with relevant rules and regulations. All relevant national or local regulations must be taken into account when planning electric equipment.

#### Important requirements from the standards

1. It must be possible to cut off all phases of the main power supply line by means of one mains connection switch. This switch must be protected against unauthorized restoration of the power supply.
2. An isolator which can be locked should be provided for each hoist if several of these, operating on one track, are fed through one and the same power supply line.
3. Each hoist must be fitted with an emergency-stop device which brings the motion drives to a standstill and interrupts the power supply to these drives.
4. A crane switch is required for
  - electrically powered cranes,
  - cross-travel drives with an output greater than 500 W.
5. Installation of a protective earth conductor, marked green/yellow over its entire length, is obligatory. It must not be possible for earth conductor current collectors to be swapped for phase collectors. Electric chain hoists are connected to the protective earth circuit of the installation. Protection of the ProfileMaster PLUS AL rails and the trailing cable power supply lines is achieved by the use of safety class II equipment or equivalent insulation. Therefore, a connection to the protective earth circuit is not necessary.

#### Power supply

The required power supply system should be selected and ordered separately according to the standard electric equipment table.

When specifying the power supply line, the total length of the supply lines along the crane runway and crane bridge must be added and checked to ensure that it is within the maximum permissible voltage drop according to [Cable union sets \(items 190, 191\) \(page 93\)](#).

This section lists the small parts sets required for assembly and installation.



## 15.2 Standard electric equipment

Selection table for installations with 2-stage TD E22-C BL chain hoist					Item	Required cable(s) on					Required number of poles on the crane bridge (PE = protective earth conductor)
Travel motion	Power supply on the crane bridge	Lifting/lowering 2 speeds	Cross travel 2 speeds	Long travel 2 speeds		the crane bridge				the crab	
					Manual		O			x	1
Electric	Trailing cable	O	O		x	2	1			1	3+PE
		O	O		A	3	1			1	3+PE
Electric with crane switch contactor		O		O	B	7		1	1	1	8+PE
	Conductor line	O		O	B				1	1	8+PE
	Trailing cable	O	O	O	A	6		1	1	1	8+PE
	Conductor line	O	O	O	A				1	1	8+PE

x = No item required

The following components must be ordered:

Item	Designation	Part no.
A	Crane bridge enclosure	772 407 45
A	RF 125 enclosure mounting bracket	851 533 44
B	Crane bridge enclosure	772 407 45
	RF 125 enclosure mounting bracket	851 533 44

The cables listed in the selection tables are not included in the electric items and must therefore be ordered separately.

Flat and round cables are supplied by the meter, whereas the cables for the travelling hoist are prepared in suitable lengths.

## 15.3 Cable union sets (items 190, 191)

Item	Designation			
190	Flat cable set	4 x 1.5 mm <sup>2</sup>	Weight [kg]	0.11
			Part no.	873 989 44
		4 x 2.5 mm <sup>2</sup>	Weight [kg]	0.15
			Part no.	873 990 44
		13 x 1.5 mm <sup>2</sup>	Weight [kg]	0.10
			Part no.	873 991 44
191	Round cable set	5 x 1.5 mm <sup>2</sup>	Weight [kg]	0.11
			Part no.	873 992 44

The cable sets include all small parts needed for the cabling and wiring of ProfileMaster PLUS AL installations when series components are used.

Assignment of the sets for the given application is described below. Contents of the cable sets:

- 873 989 44:** 2 x M20 flat cable twist-type entry glands, M20 counter-nut, M25-M20 reducer, M25 counter-nut, M20 union
- 873 990 44:** 2 x M25 flat cable twist-type entry glands, 2 x M20 counter-nuts, 2 x M20-M25 adapters, M20 union
- 873 991 44:** 2 x M25 flat cable twist-type entry glands
- 873 992 44:** 2 x M25 counter-nuts, 2 x M20 counter-nuts, 1 x M25-M20 reducer, 2 x M25 unions, 2 x M20 unions







**Assignment of cable sets:**

- Power supply to crane runway:
  - 4 x 1.5 mm<sup>2</sup> trailing cable: 1 x 873 989 44 per powerfeed point
  - 4 x 2.5 mm<sup>2</sup> trailing cable: 1 x 873 990 44 per powerfeed point
  - Conductor line: no cable set required
- Crane power supply (see table below)

Electric motion			Isolating switch on the crane	Crane power supply (per crane):			
				Conductor line	Trailing cable		
Lifting	Cross travel	Long travel			1.5 mm <sup>2</sup> cross-section		2.5 mm <sup>2</sup> cross-section
				4 x 1.5 mm <sup>2</sup>	13 x 1.5 mm <sup>2</sup>	4 x 2.5 mm <sup>2</sup>	4 x 2.5 mm <sup>2</sup> + 8 x 1.5 mm <sup>2</sup>
O							
O			O	1 x 873 992 44	1 x 873 989 44		1 x 873 990 44
O	O						
O	O		O	1 x 873 992 44	1 x 873 989 44		1 x 873 990 44
O		O		2 x 873 992 44		1 x 873 991 44	1 x 873 989 44
O		O	O	3 x 873 992 44		1 x 873 991 44 1 x 873 992 44	1 x 873 990 44 1 x 873 992 44
O	O	O		2 x 873 992 44		1 x 873 991 44	1 x 873 989 44
O	O	O	O	3 x 873 992 44		1 x 873 991 44 1 x 873 992 44	1 x 873 990 44 1 x 873 992 44

**15.4 Schematic diagrams of cable arrangements and cable clamps**

**Key to symbols**

Key to symbols		Item	Designation	Section
	Cable clamp	80	Crane girder cable clamp	<a href="#">Trailing cable, components and fittings (page 85)</a>
	Round cable (item 92), rigidly mounted on the crane bridge	81	Crab frame cable clamp	<a href="#">Trailing cable, components and fittings (page 85)</a>
	Flat cable (item 84), freely suspended	82	RF trolley cable clamp	<a href="#">Trailing cable, components and fittings (page 85)</a>
	Double-rail crab with cable entry on the hoist unit	85	Cable slider	<a href="#">Trailing cable, components and fittings (page 85)</a>
	RF (friction-wheel travel drive)	88	Mains connection switch	<a href="#">Mains connection switch/ isolating switch (item 88) (page 88)</a>
	Control element	91	Round cable and crane drive connection	<a href="#">Round cable and crane drive connection (page 87)</a>

