

Chariot à direction par chaîne 12,5T/16T/20T
Manual drive trolley 12.5T/16T/20T
Haspelfahrwerk 12,5T/16T/20T

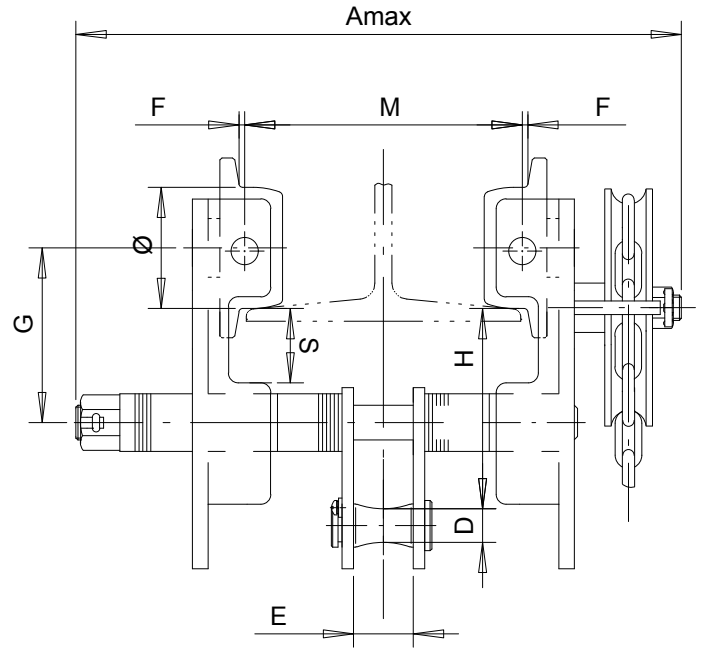
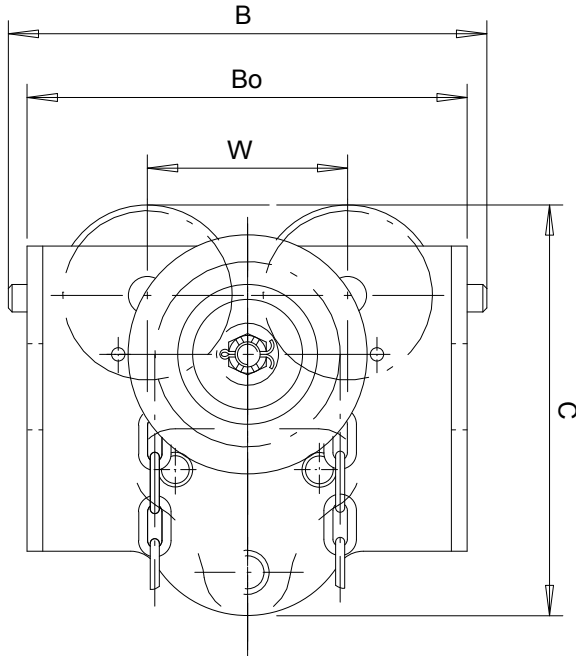

Modèle	Model		CHDHD-12.5	CHDHD-16	CHDHD-20	
Capacité (tonne)	Rated Capacity (ton)		12.5	16	20	
Effort sur chaîne pour lever charge (N)	Chain pull to lift full load (N)		240	240	250	
Rayon mini de courbe (m)	Min.radius of curve (m)		3.0	3.5	3.5	
		Amax	a	421	507	507
			b	527	613	613
		B	466	579	579	
		Bo	442	555	555	
		C	420	587	587	
		D	50	64	68	
		E	70	92	88	
		H	187	283	278	
		S	45	64	60	
		Ø	134	168	175	
		G	105	204	204	
		W	200	272	272	
Largeur de fer (m)	I-beam width range (m)	M	a	124-202	136-202	136-202
			b	188-310	188-310	188-310
Poids net kg	Net weight kg	a	125	215	220	
		b	130	220	226	