

Palan manuel et chariot combiné

Hand chain block combined with integrated trolley

Handkettenzug mit Fahrwerk in kurzer Bauart

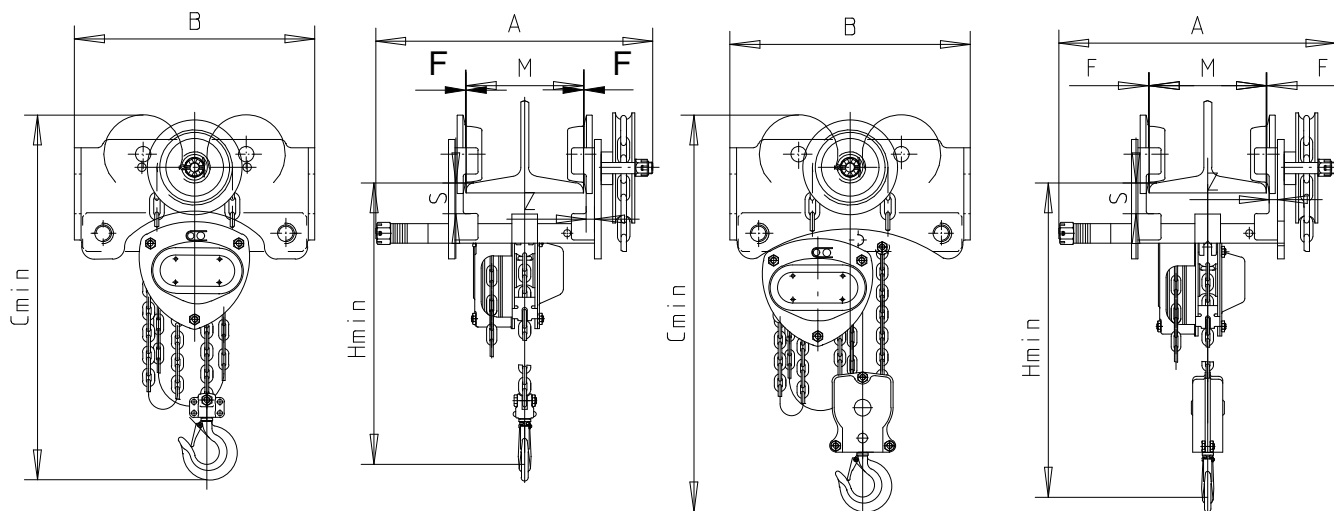

0.5t - 3t

5t

Rated Capacity	ton	0.5	1	1.5	2	3	5	
Test load	KN	7.35	14.71	22.06	29.42	44.13	61.29	
Running height	m	2.5						
Chain pull to lift full load N		25	50	70	90	95	140	
Dimensions mm	A	a	272	334	337	343	357	373
		b	322	436	439	445	459	475
	B	258	292	319	358	434	448	
	Cmin	385	451	489	551	629	758	
	Hmin	299	331	383	411	460.5	585	
	S	30	35	38	38	40	42	
	Z	7.5	10.5	10.5	12	14	15	
	F		1.5-3					
I-beam width range mm	M	a	50-152	64-203	74-203	88-203	100-203	114-203
		b	50-203	64-305	74-305	88-305	100-305	114-305
Net weight Kg	a	19	27.3	37	49.5	65	90.5	
	b	21	29.3	39	51.5	69	95.5	