

Palan manuel et chariot intégré

Hand chain block combined with integrated trolley

Handkettenzug mit Fahrwerk in kurzer Bauart

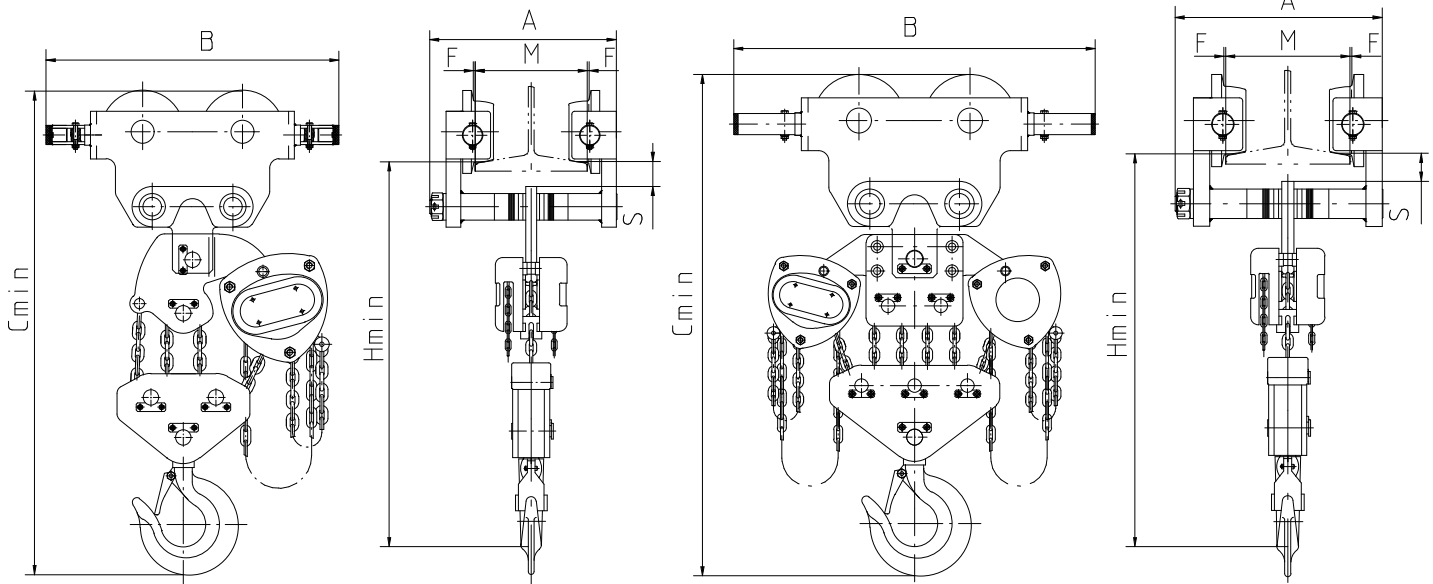

7.5t - 12.5t

16t - 20t

Rated Capacity	ton	7.5	10	12.5	16	20	
Test load	KN	98.06	122.58	153.2	196.12	245.17	
Min.radius curve	m	2.0	2.0	2.5	3.5	3.5	
Dimensions mm	A	a	372	378	406	449	449
		b	474	480	508	551	551
	B	628	636	668	757	887	
	C min	916	965	990	1020	1220	
	H min	707	745	760	780	960	
	S	45	45	50	56	58	
	F	2 ~ 3.5					
I-beam width range mm	M	a	124 ~ 203	124 ~ 203	124 ~ 203	136 ~ 203	136 ~ 203
		b	124 ~ 305	124 ~ 305	124 ~ 305	136 ~ 305	136 ~ 305
Net weight Kg	a	130	147	242	278	331	
	b	136	154	250	285	339	