

Combined hand chain block and manual push travel trolley
Palan manuel et chariot manuel a direction par poussée combinés

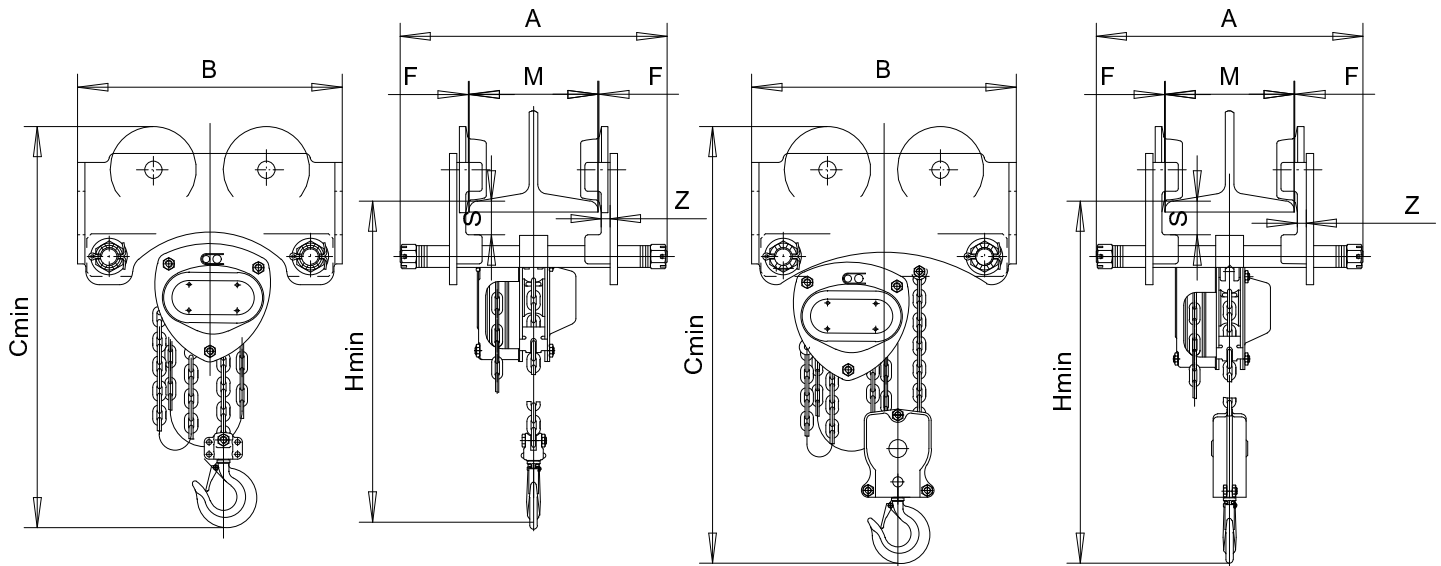

0.5t - 3t

5t

Rated Capacity	ton	0.5	1	1.5	2	3	5	
Test load	KN	7.35	14.71	22.06	29.42	44.13	61.29	
Min.radius curve	m	0.85	1.0	1.1	1.1	1.3	1.4	
Dimensions	A	a	236	303	310	317	333	355
		b	286	405	412	419	435	457
	B	258	292	319	358	434	448	
	Cmin	385	451	489	551	629	758	
	Hmin	299	331	383	411	460.5	585	
	S	30	35	38	38	40	42	
	Z	7.5	10.5	10.5	12	14	15	
	F	1.5-3						
I-beam width range	M	a	50-152	64-203	74-203	88-203	100-203	114-203
		b	50-203	64-305	74-305	88-305	100-305	114-305
Net weight	Kg	a	15	23.3	33	45.5	61	85.5
		b	17	25.3	35	47.5	65	90.5