

Accouplé à C5 chariot à direction électrique (version perpendiculaire)
Fixed to C5 electric travel trolley (perpendicular version)
Mit C5 Motorfahrwerk (Quer zur Kettenzugachse)

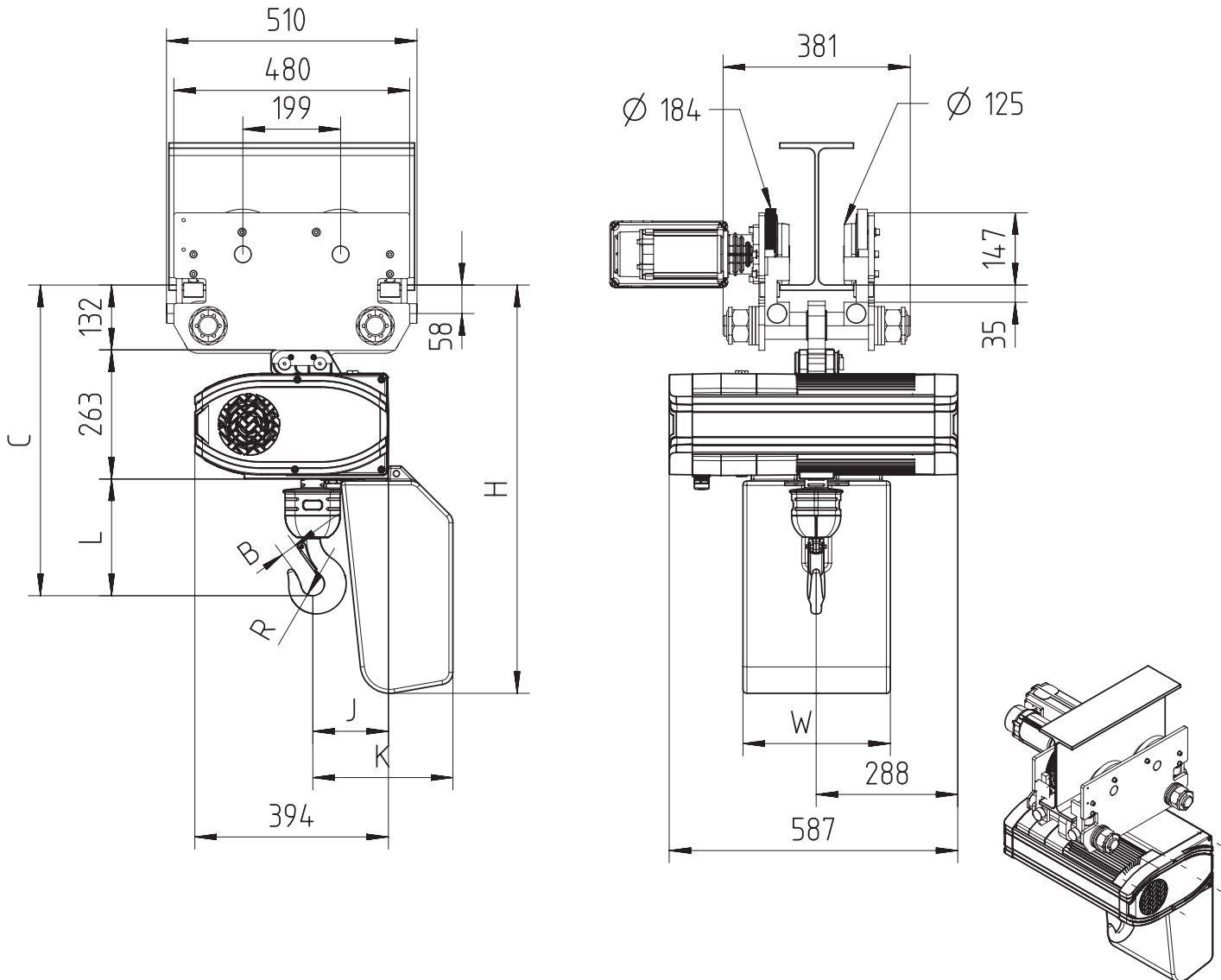

Chain Size [mm]	Falls	Chain bag max capacity [m]	Max load kg	Dimensions [mm]								Weights [kg]					
				B	C	L	R	J	K	H	W	M		Weight of 3m of chain	Total weight w/o chain		
												Classic/ GLS	Neo/ DB		Classic	Neo	GLS
11.3X31	1	12	2500	33	633	238	24	154	286	831	300	587	709	8.4	189.7		
11.3X31	1	30	2500						397	1008	350			8.4	189.7		
11.3X31	2	12	5000	41	783	388	28	203	334	831	300			8.4	193.4		
11.3X31	2	30	5000						447	1008	350			8.4	193.4		
9X27	1	12	1600	26	606	211	22	154	286	831	300			5.31	189.2		
9X27	1	30	1600						397	1008	350			5.31	189.2		

GLS = Gear Limit Switch
DB = Double Brake

SWF behält sich das Recht auf Veränderung oder Richtigstellung der oben genannten Information ohne weitere Mitteilung vor.

SWF reserves the right to alter or amend the above information without notice.

SWF se réserve le droit de modifier sans préavis les caractéristiques de son matériel.

DISCLOSED WITHOUT PRIOR WRITTEN CONSENT OF THE COMPANY . ANY COPIES OF THIS DOCUMENT MADE BY ANY METHOD MUST ALSO INCLUDE A COPY OF THIS LEGEND.

Accouplé à C3 chariot manuel (version perpendiculaire)
Fixed to push C3 trolley (perpendicular version)
Ösenaufhängung mit C3 Schiebefahrwerk (Quer zur Kettenzugachse)

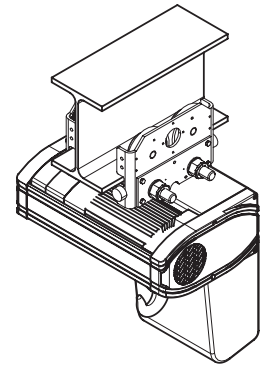
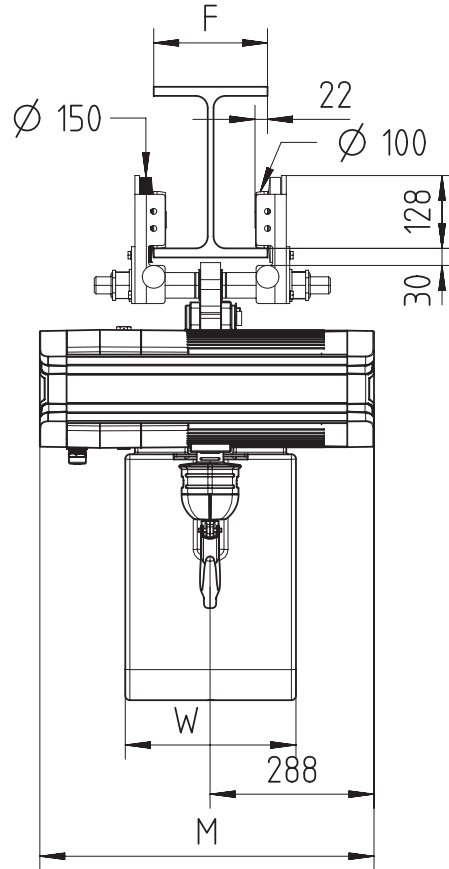
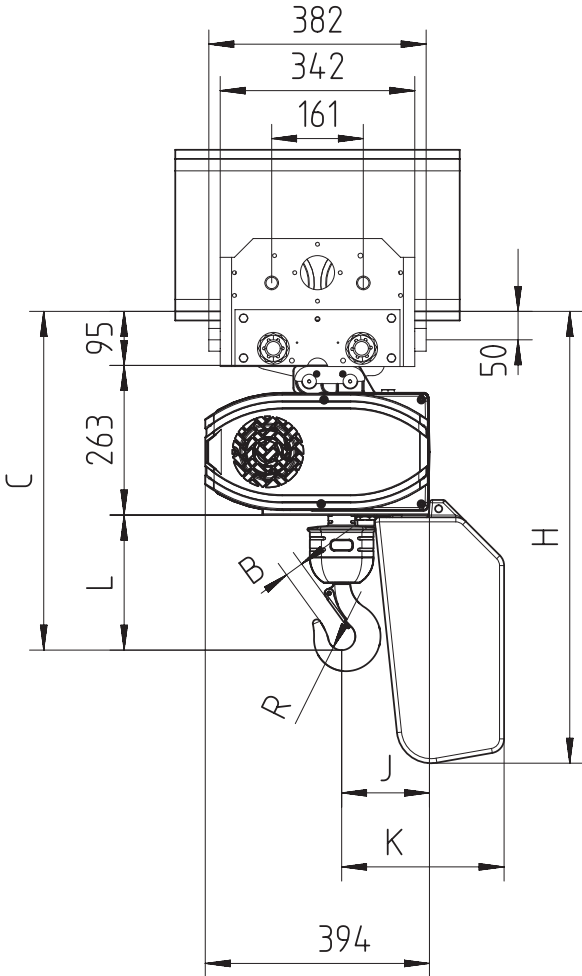

Chain Size [mm]	Falls	Chain bag max capacity [m]	Max load kg	Dimensions [mm]									Weights [kg]					
				B	C	L	R	J	K	H	W	M		Weight of 3m of chain	Total weight w/o chain			
												Classic/ GLS	Neo/ DB		Classic	Neo	GLS	DB
11.3X31	1	12	2500	33	596	238	24	154	286	794	300	587	709	8.4	155.2			
11.3X31	1	30	2500						397	971	350			8.4	155.2			
11.3X31	2	12	5000	41	746	388	28	203	334	794	300	587	709	8.4	158.9			
11.3X31	2	30	5000						447	971	350			8.4	158.9			
9X27	1	12	1600	26	569	211	22	154	286	794	300	587	709	5.31	154.7			
9X27	1	30	1600						397	971	350			5.31	154.7			

GLS = Gear Limit Switch
DB = Double Brake

Accouplé à C5 chariot manuel (version perpendiculaire)
Fixed to C5 push trolley (perpendicular version)
Ösenaufhängung mit C5 Schiebefahrwerk (Quer zur Kettenzugachse)

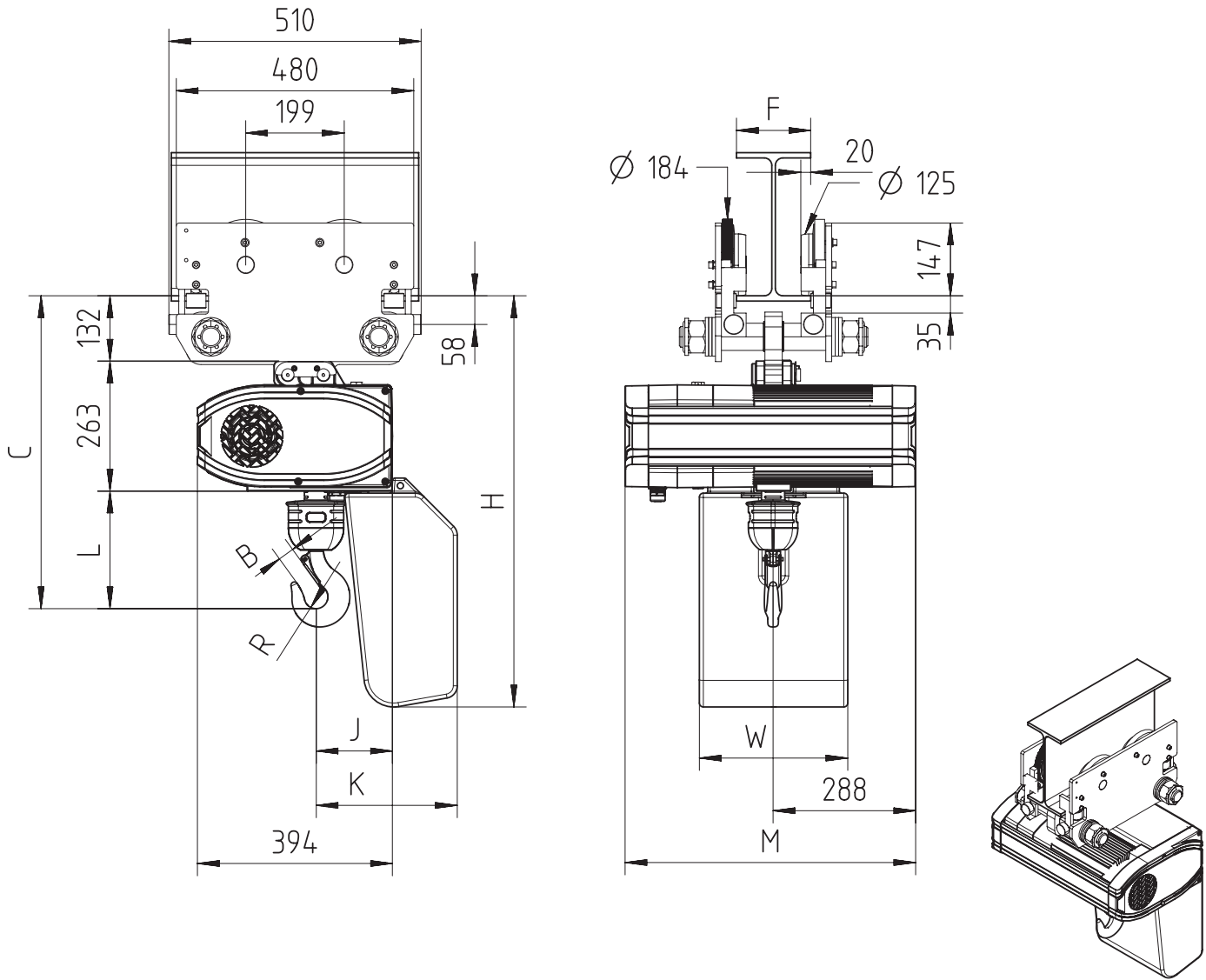

Chain Size [mm]	Falls	Chain bag max capacity [m]	Max load kg	Dimensions [mm]								Weights [kg]					
				B	C	L	R	J	K	H	W	M		Weight of 3m of chain	Total weight w/o chain		
												Classic/ GLS	Neo/ DB		Classic	Neo	GLS
11.3X31	1	12	2500	33	633	238	24	154	286	831	300	587	709	8.4	181.2		
11.3X31	1	30	2500						397	1008	350			8.4	181.2		
11.3X31	2	12	5000	41	783	388	28	203	334	831	300	587	709	8.4	184.9		
11.3X31	2	30	5000						447	1008	350			8.4	184.9		
9X27	1	12	1600	26	606	211	22	154	286	831	300	587	709	5.31	180.7		
9X27	1	30	1600						397	1008	350			5.31	180.7		

GLS = Gear Limit Switch
DB = Double Brake

SWF behält sich das Recht auf Veränderung oder Richtigstellung der oben genannten Information ohne weitere Mitteilung vor.

SWF reserves the right to alter or amend the above information without notice.

SWF se réserve le droit de modifier sans préavis les caractéristiques de son matériel.

DISCLOSED WITHOUT PRIOR WRITTEN CONSENT OF THE COMPANY . ANY COPIES OF THIS DOCUMENT MADE BY ANY METHOD MUST ALSO INCLUDE A COPY OF THIS LEGEND.

Accouplé à C3 chariot à direction électrique (version perpendiculaire)
Fixed to C3 electric travel trolley (perpendicular version)
Mit C3 Motorfahrwerk (Quer zur Kettenzugachse)

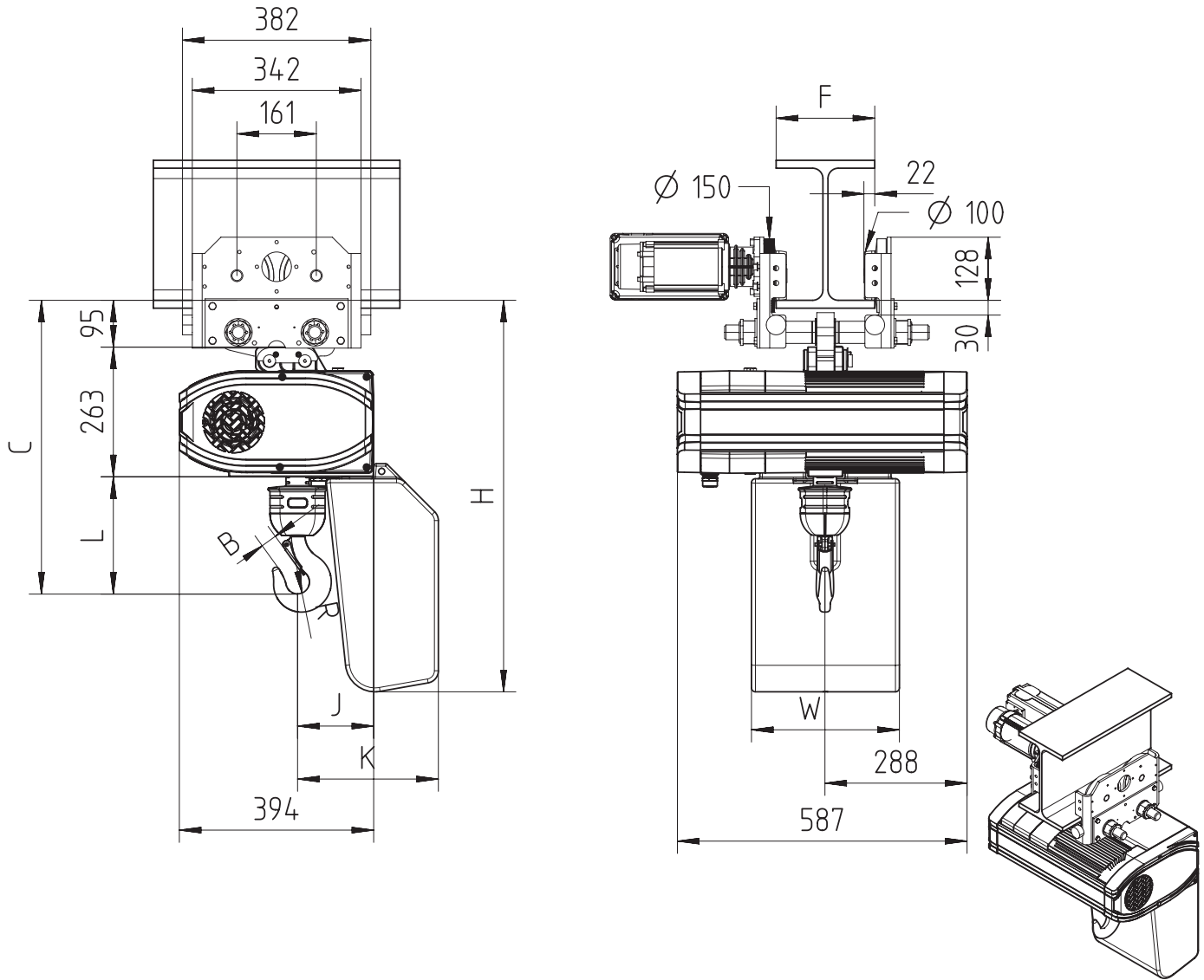

Chain Size [mm]	Falls	Chain bag max capacity [m]	Max load kg	Dimensions [mm]								Weights [kg]						
				B	C	L	R	J	K	H	W	M		Weight of 3m of chain	Total weight w/o chain			
												Classic/ GLS	Neo/ DB		Classic	Neo	GLS	DB
11.3X31	1	12	2500	33	596	238	24	154	286	794	300	587	709	8.4	163.7			
11.3X31	1	30	2500						397	971	350			8.4	163.7			
11.3X31	2	12	5000	41	746	388	28	203	334	794	300	587	709	8.4	167.4			
11.3X31	2	30	5000						447	971	350			8.4	167.4			
9X27	1	12	1600	26	569	211	22	154	286	794	300	587	709	5.31	163.2			
9X27	1	30	1600						397	971	350			5.31	163.2			

GLS = Gear Limit Switch
DB = Double Brake

SWF behält sich das Recht auf Veränderung oder Richtigstellung der oben genannten Information ohne weitere Mitteilung vor.

SWF reserves the right to alter or amend the above information without notice.

SWF se réserve le droit de modifier sans préavis les caractéristiques de son matériel.

DISCLOSED WITHOUT PRIOR WRITTEN CONSENT OF THE COMPANY . ANY COPIES OF THIS DOCUMENT MADE BY ANY METHOD MUST ALSO INCLUDE A COPY OF THIS LEGEND.

Ortsfest mit Hakenaufhängung (Quer zur Kettenzugachse)
Hook suspended (perpendicular version)
Fixe suspendu par crochet (version perpendiculaire)

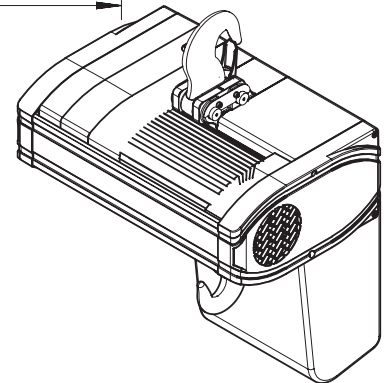
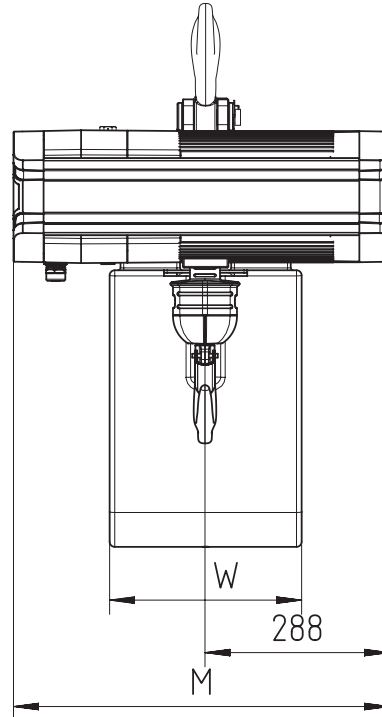
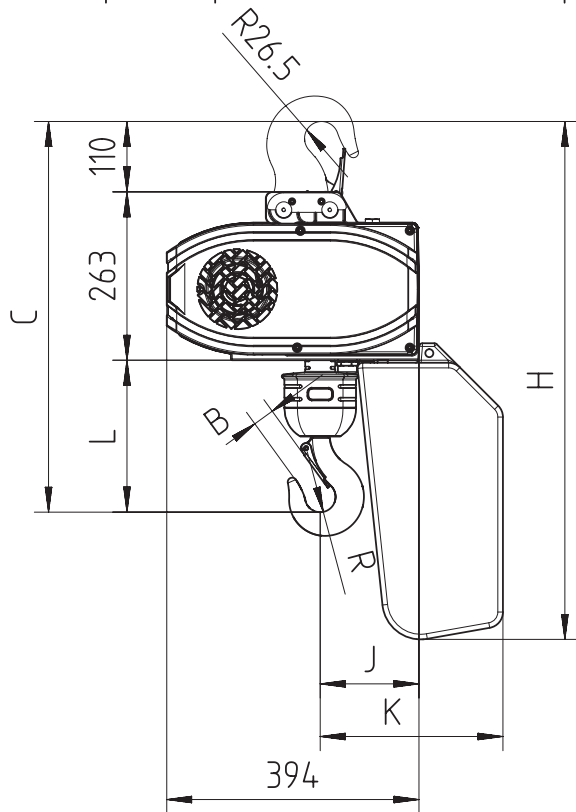

Chain Size [mm]	Falls	Chain bag max capacity [m]	Max load kg	Dimensions [mm]								Weights [kg]						
				B	C	L	R	J	K	H	W	M		Weight of 3m of chain	Total weight w/o chain			
												Classic/ GLS	Neo/ DB		Classic	Neo	GLS	DB
11.3X31	1	12	2500	33	611	238	24	154	286	809	300	587	709	8.4	107.7			
11.3X31	1	30	2500						397	986	350			8.4	107.7			
11.3X31	2	12	5000	41	761	388	28	203	334	809	300	587	709	8.4	111.4			
11.3X31	2	30	5000						447	986	350			8.4	111.4			
9X27	1	12	1600	26	584	211	22	154	286	809	300	587	709	5.31	107.2			
9X27	1	30	1600						397	986	350			5.31	107.2			

GLS = Gear Limit Switch
DB = Double Brake

SWF behält sich das Recht auf Veränderung oder Richtigstellung der oben genannten Information ohne weitere Mitteilung vor.

SWF reserves the right to alter or amend the above information without notice.

SWF se réserve le droit de modifier sans préavis les caractéristiques de son matériel.

DISCLOSED WITHOUT PRIOR WRITTEN CONSENT OF THE COMPANY . ANY COPIES OF THIS DOCUMENT MADE BY ANY METHOD MUST ALSO INCLUDE A COPY OF THIS LEGEND.